



# DYNAMIX

## HomePNA 3.0 Ethernet Bridge



## User's Manual

## **INTRODUCTION**

This HomePNA to Ethernet bridge connects any Ethernet device to a high speed access device or to a Home Networking LAN for Internet access. This bridge brings you the newest Ethernet compatible technology that uses the telephone wiring as the network's physical wiring thereby eliminating the need to install new wiring. It is designed to operate on the telephone wire installed in homes.

This bridge allows you to connect PCs and Ethernet enabled devices, such as Switch, HUB and printers, to a Home Networking LAN by simply plugging into the existing RJ-11 jacks.

### **Features**

- Plug & Play
- Using existing phone jacks to build a network
- Shares high speed Internet access and streaming video
- 1 port 128Mbps connection compliant with HomePNA 3.0 standard
- 2 Standard 10/100BaseT Fast Ethernet ports for connecting to Ethernet or cable modem
- 10/100Mbps Auto Negotiation Support
- MDI/MDIX Auto Crossover Support
- QoS Priority Mapping Support

# HARDWARE INSTALLATION

## Parts Names and Functions

### LED Indicators on the Front Panel

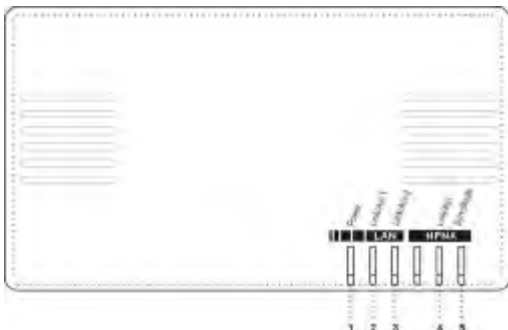

	LED	Status		
		Glowing	Dimming	Flashing
①	<b>Power</b>	Powered by DC5V	Not powered	N/A
②	<b>LAN Link /Act</b>	LAN 1 Link	Disconnect or Link fail	Receive or Transmit
③	<b>LAN Link /Act</b>	LAN 2 Link	Disconnect or Link fail	Receive or Transmit
④	<b>HPNA Link /Act</b>	HPNA Link	Disconnect or Link fail	Receive or Transmit
⑤	<b>HPNA SyncMode</b>	Sync. Mode	Async. Mode	N/A

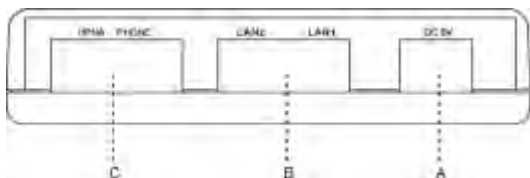

## Ports on the Rear Panel





	Port Name	Type	Functions
A	<b>DC5V</b>	DC	Connects to the power adapter plug.
B	<b>LAN1/LAN2 (Ethernet)</b>	RJ-45	Connects to Ethernet port on FTTH/xDSL Modem or Switch for Internet Access.
C	<b>HPNA &amp; PHONE</b>	RJ-11	Connects to other HomePNA devices or Telephone or Phone port of ADSL splitter

## Essential Hardwares

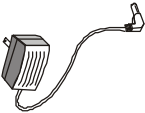
Items Included	Description	Purpose
	HomePNA to Ethernet Bridge	Main Unit

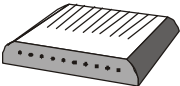
	Telephone wire	Connects from HPNA Port to phone jack on the wall outlet.
	CAT5 Ethernet cable	Connects from LAN port to Ethernet enabled devices as PC
	DC5V Power adapter	Connects from Power port of the main unit into a wall outlet

<b>Additional Items (Not included)</b>	<b>Description</b>
	A well-installed WAN environment (Cable Modem or xDSL Modem)
	A well-installed LAN environment

## Hardware Connections

1. Select a convenient location for the bridge near the PC or Ethernet device to which it will be connected. The bridge should be kept away from excessive heat.

2. Using one telephone wire to connect the **HPNA** port to RJ-11 jack on the wall. Using another telephone wire to connect the other **Phone** port to a telephone set (or connect the **Phone** port to “phone” port of splitter of ADSL modem).
3. Connect the **LAN1/LAN2** port to your Ethernet-equipped device.
4. Connect the power adapter to the **DC5V** port into a wall outlet.

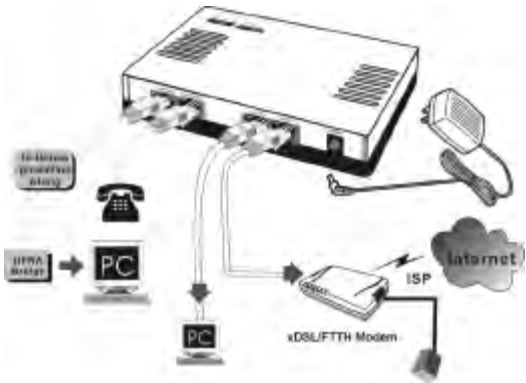

The figure above shows how to connect a cable modem to a home phoneline network. Follow the same steps to connect any Ethernet device such as a HUB or printer, to a home phoneline network.

Now you should have connected the **LAN** port, **HPNA** port and the **DC5V** port to the appropriate devices or lines. LED will be as:

POWER                      ON

LAN Link/Act	ON
HPNA Link/Act	ON

For more information on LEDs, see section  
**"LED Indicators on the Front Panel"**

## **TROUBLESHOOTING**

The bridge has been designed to be a reliable and easy to use connection device. Please refer to the list below to aid in troubleshooting.

### **The Power (green) LED is off.**

- *Make sure the power adapter is properly plugged into a live electrical outlet.*

### **The LAN(Ethernet) or HPNA Link/Act LED is off.**

- *Make sure the connection to these two ports is secure.*
- *The Ethernet or HomePNA device to which you are connected should be powered on and properly configured.*

# **SPECIFICATIONS**

## **Standards**

- IEEE 802.3 10BaseT Ethernet compliant
- IEEE 802.3u 100BaseT Fast Ethernet compliant
- HomePNA 3.0 specifications compliant

## **Data Rates**

- Home Networking: 128 Mbps
- Ethernet: 10/100 Mbps

## **Distances**

- Home Networking: 600 meter maximum between the two farthest nodes on the LAN
- Ethernet: 100 meter maximum

## **Power Consumption**

- 5V DC IN, Less than 4 watt

## **Certifications**

- CE, FCC Part 15
- FCC Part 68

## **LEDs**

- Power
- Ethernet Link/Activity
- HPNA Link/Activity and SyncMode

## **Connectors**

- Two RJ-11, one for connecting with HomePNA device, and one for telephone bypass
- Two RJ-45 for 10/100M Ethernet

## **Cables**

- Home Networking: standard home phone wire
- Fast Ethernet: CAT5 or better UTP