



DYNAMIX 3000

G.SHDSL TDM Based Rack



User Manual

Dynamix 3000 G.SHDSL TDM Based Rack
Bridged Ethernet, G.703 E1, DataCom V.35, X.21, RS-530, & RS-449 over SHDSL

Contents:

SUMMARY	5
CHAPTER 1: PRODUCT DESCRIPTION.....	6
1.1 INTRODUCTION	6
1.2 PRODUCT INTERACTION.....	6
1.2.1 Operation	7
1.2.2 Rate Adjustment	8
1.2.3 Line Card's System Interface	8
1.3 PHYSICAL DESCRIPTION	10
1.4 SYSTEM MANAGEMENT.....	10
1.4.1 External PC Interaction.....	10
1.4.2 SNMP management	10
CHAPTER 2: SYSTEM OVERVIEW.....	11
2.1 GENERAL	11
2.2 SYSTEM DESCRIPTION.....	11
2.3 SHDSL TRANSMISSION	11
2.4 REAL-TIME PERFORMANCE MONITORING.....	12
2.4.1 Monitored Parameters	12
2.4.2 History Reports.....	12
2.4.3 Status Readouts	13
2.5 INTERFACE CONFIGURATION	13
2.6 INTERFACE TYPE.....	13
2.7 ALARM MANAGEMENT	13
2.8 DIAGNOSTICS	13

**Dynamix 3000 G.SHDSL TDM Based Rack
Bridged Ethernet, G.703 E1, DataCom V.35, X.21, RS-530, & RS-449 over SHDSL**

2.8.1	Near End Loopback.....	14
2.8.2	Local Loopback	14
2.8.3	Remote loopback	14
2.8.4	Remote payload Loopback.....	15
CHAPTER 3: APPLICATIONS		16
3.1	FAR REACH SINGLE PAIR E1 OR T1	16
3.2	FAST SYNCHRONOUS INTERFACES	16
3.3	SELECTABLE DATA RATES.....	17
3.4	PACKET INTERFACE: ETHERNET.....	18
CHAPTER 4: INSTALLATION		19
4.1	GENERAL.....	19
4.2	UNPACKING YOUR DYNAMIX 3000	19
4.2.1	Tools Needed.....	19
4.2.2	Unpacking.....	19
4.3	SHELF INSTALLATION.....	20
4.3.1	Power Connection	20
4.3.2	Alarm Connection	21
4.3.3	SHDSL Loop Connection.....	21
4.4	MIU AND LINE CARD (STU) INSTALLATION	21
4.4.1	MIU Functional Description	22
4.5	STU INSTALLATION.....	23
4.5.1	Installation Procedure.....	23
4.6	LED DESCRIPTIONS	24
CHAPTER 5: MIU/CID CONFIGURATION/OPERATION		25

Dynamix 3000 G.SHDSL TDM Based Rack
Bridged Ethernet, G.703 E1, DataCom V.35, X.21, RS-530, & RS-449 over SHDSL

5.1	TERMINAL OPERATION	25
5.2	SCREEN DEFINITION	25
5.3	PARAMETER DESCRIPTION OF THIS MANUAL	27
5.4	MAIN MENU OF THE CID	28
5.5	CONFIGURATION MENU	29
5.5.1	System Setting	29
5.5.2	E1-T1 Interface Setting	31
5.5.3	DTE Interface Setting	32
5.5.4	DSL Interface Setting	33
5.5.5	E1-T1 PM Threshold Setting	34
5.5.6	DSL PM Threshold Setting	35
5.5.7	Recall configuration	36
5.5.8	Store Current Configuration	37
5.6	SURVEILLANCE	37
5.6.1	Retrieve Alarm	38
5.6.2	Status Read Out	39
5.6.3	Retrieve PM	42
5.6.5	Retrieve & Reset Event Logs	47
5.6.6	Retrieve Version	49
5.6.7	Reset PM Data	50
5.7	MAINTENANCE	51
5.7.1	Loopback Control	51
5.7.2	PRBS Test	52
5.8	MISCELLANEA	53
5.8.1	Set System Time	53
5.8.2	Set TCP/IP parameters of SNMP agent	54

Dynamix 3000 G.SHDSL TDM Based Rack
Bridged Ethernet, G.703 E1, DataCom V.35, X.21, RS-530, & RS-449 over SHDSL

5.8.3	Set Screen Refresh Timer	54
5.8.4	User Account Management	55
5.9	RETRIEVE NEW EVENT	58
APPENDIX A:	INTERFACE PIN ASSIGNMENTS	59
APPENDIX B:	ACRONYM DEFINITIONS	62
APPENDIX C:	ETHERNET INTERFACE SETTING	64
APPENDIX D:	LOOPBACK ILLUSTRATION	66
APPENDIX E:	DYNAMIX 3000 SPECIFICATION	67
APPENDIX E:	DYNAMIX 3000 DUMMY BOARD	68
APPENDIX F:	REMOTE CONTROL THOUGH TELNET	69

Summary

Today's bandwidth requirement applications, such as Internet access, remote LAN access, teleconferencing, workgroup and data sharing, telecommuting and numerous varieties of digital video services and the increasing volume of traditional data, are driving demand for high-speed data network access.

We, Dynamix Promotions Limited, design, develop and market transmission systems based on Digital Subscriber Line (DSL) technology for copper wire plant. They support all contemporary data rates, from 64kbps to multi-megabit symmetric and asymmetric transmission for voice, video and data communications over a twisted copper pair. Our access systems link enterprise LANs and Network Service Providers over private and public networks across the local loop, the connection between the customer and the first network node.

Deploying in nearly any symmetric application requiring bandwidths from 192kbps to 2.3Mbps, G.SHDSL is poised for the best cost-effective solution for business-based applications such as Internet access and remote LAN access. By adapting G.SHDSL, Small to Medium Enterprises (SME) no longer afford the expensive enterprise data solutions such as T1/E1. **DYNAMIX 3000** offers Telecom service providers the best cost-effective solution for immediate implementation of replacing T1/E1 leased line. **DYNAMIX 3000** provides full duplex capability of supporting selected symmetric user data rates of T1, E1 or n x 64 kbit/s (range from 192 kbit/s to 2 304 kbit/s) leased line services or Ethernet interface extension using a Trellis Coded Pulse Amplitude Modulation (TCPAM) line code over one non-loaded two-wire metallic cable pair. The line speed for transmitted and received data shall be multiple for lengthening the transmission distance. These selectable line rates empower Telecom to create high-bandwidth service offerings or select the proper speed for distance-sensitive deployments, thereby exploiting the high-bandwidth efficiently and fitting subscribers' needs simultaneously.

Chapter 1: Product Description

1.1 Introduction

The DYNAMIX 3000 SHDSL access system provides high-speed data access over single-pair copper wires. It can transmit up to 2.304 Mbps V.35 or Ethernet signal without a repeater for more than 7 Km (24 AWG line) at a Bit Error Rate of less than 10⁻⁷. Using SHDSL transmission technology, the DYNAMIX 3000 SHDSL network access system allows fiber quality transmission on a single pair of copper wire. Using lower gauge larger copper wire may allow you to attain greater distances.

1.2 Product Interaction

DYNAMIX 3000 shelf type CO (Central Office) includes one shelf which is equipped with one Maintenance Interface Unit (MIU) plus up to 15 Multi-rate DSL Terminal Unit (STU). Used in conjunction with the DYNAMIX 3000 standalone, the unit provides repeat-less data transport of up to 2.304 Mbps, over a single pair of unconditioned copper wire. The rate can be automatically adjusted to synchronize at the highest possible rates (see table 1), corresponding to the distance between the local and remote units (see table 1). Alternatively, the data rate is software selectable at any of the available Nx64 kbps rates where N is from 3 to 36.

Table1 : SHDSL Transmission Specification

Chart 1: SHDSL E1 Transmission Specification (Noise Free)

DATA (kbps) DIA	2048	1544	1024	768	512	384	256	192	128
0.4mm	3200m	3600m	4500m	4800m	5100m	5300m	5700m	6300m	6500m
0.5mm	3600m	3900m	4800m	5100m	5800m	6300m	7400m	8000m	8400m

Dynamix 3000 G.SHDSL TDM Based Rack
Bridged Ethernet, G.703 E1, DataCom V.35, X.21, RS-530, & RS-449 over SHDSL

Noise-free reach on PE 0.4mm wire

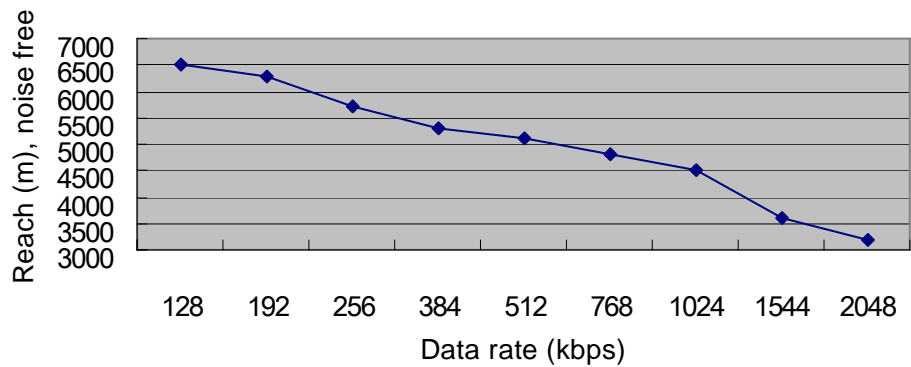

Noise-free reach on PE 0.5mm wire

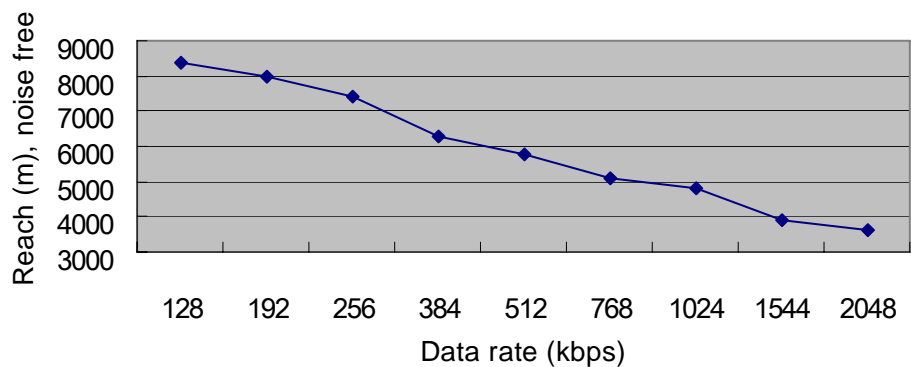

1.2.1 Operation

The outlook of shelf-type DYNAMIX 3000 is shown below:



Figure1.1 DYNAMIX 3000 front view

Dynamix 3000 G.SHDSL TDM Based Rack Bridged Ethernet, G.703 E1, DataCom V.35, X.21, RS-530, & RS-449 over SHDSL

In E1 or Fractional E1 mode (also in T1 or Fractional T1 mode), the equipment (i.e.: router or PBX) in the remote side supplies data at full or fractional E1 speed to the G.703 data port of the DYNAMIX 3000 desktop or shelf-type STU-R. The DYNAMIX 3000 produces a digitized data stream, which is transmitted over the single copper pair to the line port of its associated DYNAMIX 3000 shelf-type MTU-C. The DYNAMIX 3000 STU-C then directs the data stream to the central office switch or other central office equipment for transmission to its destination.

If being equipped with V.35 and Ethernet interface, DYNAMIX 3000 provides the data rate up to 2.304 Mbps (E1 is up to 2.048Mbps and T1 is up to 1.544). DYNAMIX 3000, designed by advanced technologies, is with the functions of coding, scrambling, format conversion, keep-alive signal stuffing & de-stuffing.

1.2.2 Rate Adjustment

From MIU, payload rate can be set manually or automatically. When it is set to automatic adjustment, the payload rate can be automatically adjusted from the highest rate down until it finds the highest possible speed it can sync to the remote unit, thereby maximizing the rate and reach. If the manual rate adjustment is selected, the line rate based on what fixed rate service is desired. Utilizing the V.35, RS-449, EIA-530 or 10BaseT data port, the DYNAMIX 3000 SHDSL system can support data rates up to 2.304 Mbps.

1.2.3 Line Card's System Interface

The DYNAMIX 3000 system supports four kinds of the MTU interfaces. Each interface provides different high-speed digital interfaces, which includes Ethernet Remote Bridge (10 BaseT), EIA-530/RS-449/V.35, T1 and E1 (G.703). Configurable items, system alarms, diagnostics, and transmission line history all differ depending on the interface type.

SHDSL specification is listed below :

- Data Rate : $n \times 64 + i \times 8$ Kbps, $3 \leq n \leq 36$ and $0 \leq i \leq 7$, 192 ~ 231Kbps.
- Symbol Rate : $(\text{Data rate} + 8000) / 3$ symbol/sec.
- Modulation Method : 16-TCPAM
- Impedance : 135 ohms

**Dynamix 3000 G.SHDSL TDM Based Rack
Bridged Ethernet, G.703 E1, DataCom V.35, X.21, RS-530, & RS-449 over SHDSL**

1.2.3.1 Ethernet Interface

As the figure shown, DYNAMIX 3000 SHDSL provides one Ethernet interface (IEEE standard 802.3/802.3u) that connects to an Ethernet LAN running at 10/100 Mbps. The Ethernet Interface's bridging capability operates as a self-learning bridge specified in the IEEE 802.1d full protocol transparent bridging function. It also supports auto sensing and half/full duplex configurable function. Moreover, its LAN table could store 4,096 MAC address and Packet filtering function is also supported.

1.2.3.2 EIA-530/RS-449 and V.35 Interface

DYNAMIX 3000 supports V.35, RS-449 and EIA-530. These interfaces have the same characteristics, which are listed below:

- Bit Rate : $N \times 64 \text{Kbps}$, $3 \leq N \leq 36$, 192, 256, 384, 512, 768, 1024, 1168, 1280, 1544, 2048, 2312 Kbps
- Clock Source : Internal, DSL or DTE
- The I/O connectors: The pin lists for the interface connectors appear in Appendix A.
- RS-449 interface uses the EIA-530 interface module in combination with a converter cable, which adapts the DB25 connector to DB37 connector.
- V.35 interface uses the EIA-530 interface module in combination with a converter cable, which adapts the DB25 connector to M34F connector.

1.2.3.3 G.703 (E1)

DYNAMIX 3000 follows ITU-T G.703 standard, providing standard E1 interface. Its features are listed below :

- Bit Rate : $N \times 64 \text{Kbps}$, $3 \leq N \leq 32$, 192 ~ 2048Kbps。
- Frame Format : UNFRAMED or Structured FRAME. Three modes are selectable, FAS, FAS+CRC and UNFRAME.
- Impedance : 120 ohms or 75ohms。
- Line Code : HDB3 (High Density Bipolar of Order 3)。



**Dynamix 3000 G.SHDSL TDM Based Rack
Bridged Ethernet, G.703 E1, DataCom V.35, X.21, RS-530, & RS-449 over SHDSL**

1.2.3.4 T1

DYNAMIX 3000 follows ANSI T1.403 standard providing standard T1 interface:

- Bit Rate : $N \times 64\text{Kbps}$, $3 \leq N \leq 24$, 192 ~ 1544Kbps.
- Frame Format : SF, ESF and UNFRAMED are selectable.
- Impedance : 100 ohms.
- Line Code : AMI or B8ZS.

Note: E1/T1 interface will fill 8-bits "11111111" in unused time slot.



1.3 Physical Description

The model illustrated in Figure 1.1, the DYNAMIX 3000 shelf-type, is a system that can be mounted on standard 19" or 23" rack. The size of the rack is 438 mm wide, 220 mm high and 320 mm deep, of approximately 5 U high. It weights approximately 5 Kg when all 16 slots are empty. It can accommodate up to 15 MTU units plus one MIU unit. Each of the different types of MTU can be inserted in any one of the 15 available slots. It is noted, however, that MIU can only be inserted into slot 0.

1.4 System Management

You can manage the DYNAMIX 3000 system using a terminal or PC connected to the CID port in the MIU. You can either:

- Define or change an operating parameter of the system or,
- Display the status and alarm of the system.

1.4.1 External PC Interaction

The MIU includes an RS-232 port marked CID for connection to a terminal at baud rate of 9600, no parity, 1 stop bit and 8 bits. Chapter 5 contains detailed supervisory port operating directions.

1.4.2 SNMP management

MIU is built-in SNMP Agent, supporting SNMP V1(RFC 1157), V2(RFC 1213) , and MIB (Management Information Base) is comply with RFC standard "the Structure and Identification of Management Information" (RFC 1155) and "Concise MIB Definition" (RFC1212). SHDSL is comply with IETF RFC "Managed Objects for SHDSL Line" (RFC 3276) and T1/E1 is comply with RFC 2495.

Chapter 2: System Overview

2.1 General

The following section describes the DYNAMIX 3000 access system, DSL transmission, performance monitoring, and configuration, alarm management, diagnostics and common applications.

2.2 System Description

The typical DYNAMIX 3000 SHDSL access system consists of a DYNAMIX 3000 at the customer site interfacing with a DYNAMIX 3000 line card at the central office over a Symmetric Digital Subscriber Line transmission line. The system transmits data symmetrically, at the same rate in both directions, over one pair of copper wires. DYNAMIX 3000 allows existing and new telephone companies to expeditiously and economically providing this high-speed access to their customers. In order to satisfy increasing demand for high data rate services, DYNAMIX 3000 provides transmission over a single copper pair more than doubling the transmission capacity of the existing copper plant. The DYNAMIX 3000 single-pair SHDSL access system maximizes network performance and provisioning flexibility by providing automatic rate/reach adjustment at the various symmetric data rates (see Table 1).

DYNAMIX 3000 is configured and managed locally via a VT-100 type Terminal connected to the unit through the CID port on the rear of the unit. It can also be configured and managed remotely via a terminal connected to the far-end DYNAMIX 3000.

2.3 SHDSL Transmission

Today's bandwidth-hungry applications such as Internet access, remote LAN access, teleconferencing, workgroup and data sharing, telecommuting and numerous varieties of digital video services are driving today's demand for high-speed data network access. These content rich applications have put extraordinary stress on that vital connection between the customer and the first network node... the local loop. To address this need for higher bandwidth and to minimize the bottleneck at the local loop, the telecommunications industry has developed a set of new technologies, the most significant of which is Digital Subscriber Line (DSL) transmission.

Many types of DSL have been developed for various applications. Dynamix Promotions Limited SHDSL address both the need for higher bandwidth and the efficient use of existing copper by combining the latest SHDSL technology to transmit and receive traffic from 64kbps to 2.304 Mb/s and up to 6,300 meters while using only one-pair of 24 AWG copper wire.

Dynamix 3000 G.SHDSL TDM Based Rack

Bridged Ethernet, G.703 E1, DataCom V.35, X.21, RS-530, & RS-449 over SHDSL

Because only one pair of copper wire is needed with SHDSL technology, the capacity of the local loop infrastructure is enhanced dramatically. The multi-rate capability of the DYNAMIX 3000 SHDSL access system provides needed flexibility for service providers deploying today's digital services.

2.4 Real-time Performance Monitoring

The system provides extensive real-time, non-disruptive monitoring of system performance. DSL transmission and interface port parameters are continuously monitored. Current and historical data is available to assist you in identify sources of problems during troubleshooting.

2.4.1 Monitored Parameters

Signal/Noise Ratio: This is a DSL transmission parameter, measured in dB, which indicates the Signal-to-Noise (S/N) ratio at a receiver point. The signal-to-noise value is available on the CID's status screen and the value is updated every second.

DSL CRC-6: This is a 6-bit word in every DSL frame, representing a calculation based on all the bits in that frame except for FAW and CRC-6 bit word. Any mismatch at the receiver, between the received CRC-6 and the one calculated based on the received data in the frame, indicates one or more bits were received in error in that second and it is considered an Errored Second (ES).

DSL Sync Loss: To assure proper synchronization between DSL transceivers, a sync word is generated in every frame. A sync loss is declared when one or more bits in five consecutive sync words are detected in error. When this happens, the entire second of data is considered an Unavailable Second (UAS).

2.4.2 History Reports

Based on detected parameters, the following derived performance parameters are calculated:

- **Error Seconds (ES):** a second in which at least 1 CRC-6 error is detected.
- **Sever Error Seconds (SES):** a second in which at least 150 CRC-6 errors are detected.
- **Unavailable Seconds (UAS):** a second in which one or more sync loss event has occurred.

Cumulative counts of these parameters are displayed via the console as discussed in Chapter 5 "Configuration/Operation." The readout displays the total count of each parameter since the last time the count was cleared.

2.4.3 Status Readouts

In addition to history reports, the DYNAMIX 3000 provides current status readouts via CID. The Status menu displays the signal/noise ratio as well as loss of sync or errored CRC. For the synchronous interfaces such as V.35, the status of clock and control lead is shown. For the G.703 interface, such status items as HDB3 detected, frame bit error, carrier loss, yellow alarm and sync loss are indicated if they are presented.

2.5 Interface Configuration

Parameters can be changed by using CID. When using a terminal, the parameters are selected from the Configuration menu.

2.6 Interface Type

The DYNAMIX 3000 is configured as DCE and is provided with a female connector for V.35, EIA-530, RS-449 and X.21 interfaces. Appendix A lists each of the signals, pin numbers, and their relative direction for the different interfaces. G.703 (E1) and T1 interfaces are available.

2.7 Alarm management

The DYNAMIX 3000 includes alarm to alert you of problem conditions on both the DSL transmission facility and the data interface. On the DSL line, loss of Sync will activate an alarm, independent of the access interfaces:

Loss of Sync: This alarm indicates that the facility cannot transmit data until the DYNAMIX 3000 can re-synchronize itself. This is always considered an alarm. The alarm indication is shown as a local and a remote sync loss.

On the G.703 and T1 interfaces, numerous alarm conditions will be reported if they are present:

- Loss of Frame (LOF)
- BPV Detected
- RAI/YEL: Remote alarm indicator/Yellow alarm
- AIS: Alarm indication signal
- CRC Error
- LOS: Loss of signal

2.8 Diagnostics

In addition to the real-time, non-disruptive performance monitoring discussed in Section 2.4, the DYNAMIX 3000 System provides for disruptive (out-of-service) diagnostic testing. For detailed Loopback points, please refer to Appendix D Loopback Diagram. The DYNAMIX 3000 system does this by incorporating four loopback modes as follows:

2.8.1 Near End Loopback

In this mode, The NLB capability is set up inside STU-C/STU-R as close as possible to the network side interfaces. The NLB is capable of control (activation and deactivation) by CID. The received signal is sent to the loop during the NLB is activated. For example, if Near End Loopback is activated at STU-C, the direction of Near End Loopback would be like (A) in figure 2.1.

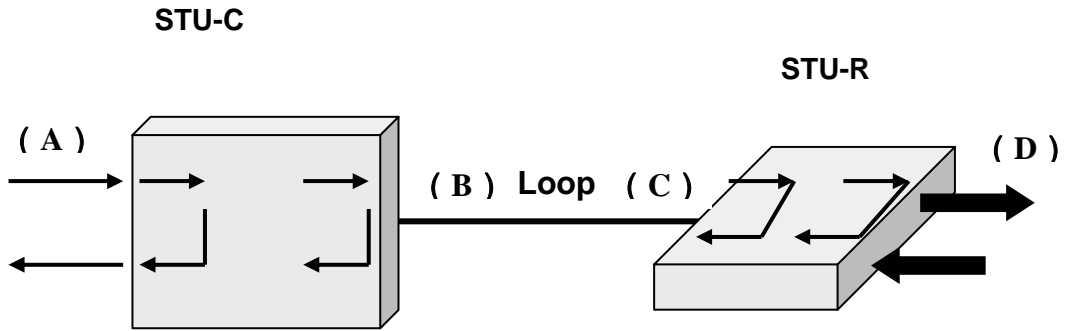

Figure 2.1 Near end Loopback

2.8.2 Local Loopback

The local loopback capability is set up inside STU-C/STU-R as close as possible to the loop interfaces. The local loopback is capable of control (activation and deactivation) by CID. The received signal is sent to the loop during local loopback. For example, if local loopback is activated at STU-C, the direction of local loopback would be like (B) in figure 2.2

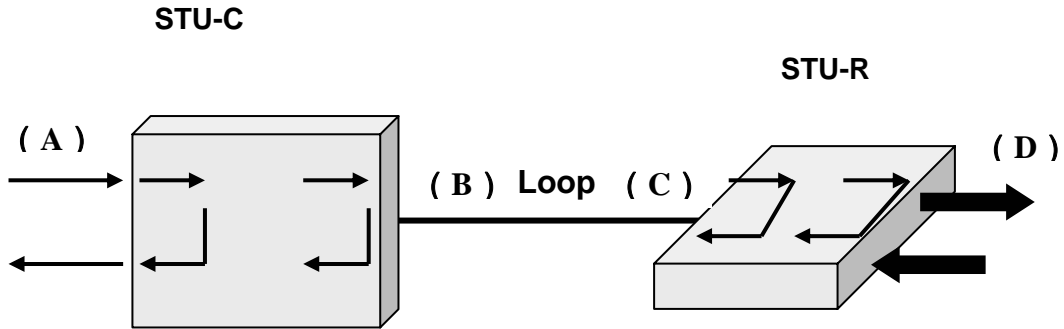

Figure 2.2 Local Loopback

2.8.3 Remote loopback

The Remote Loopback is able to be activated and deactivated through EOC via CID interfaces. This loopback is used for checking the loop and transceiver units of STU-C/STU-R. The received signal is sent to network side interface during the RLB

loopback. For example, if Remote Loopback is activated at STU-C, the direction of local loopback would be like (c) in figure 2.3

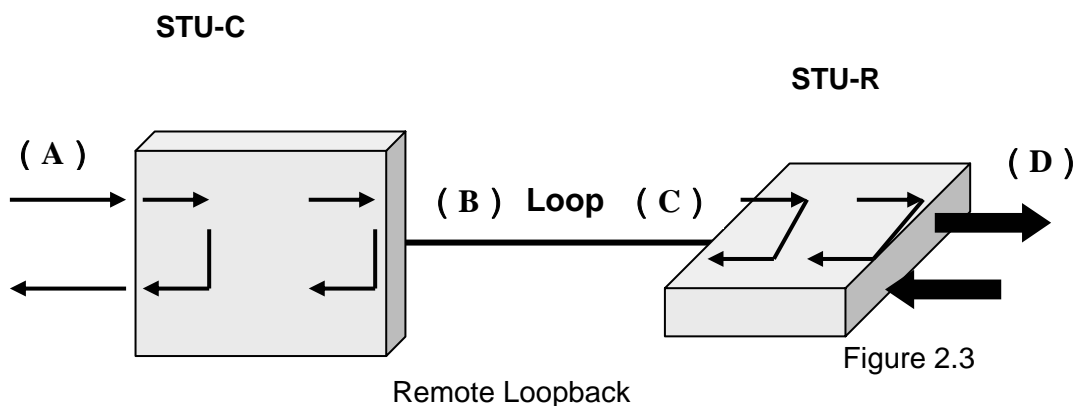

Figure 2.3

2.8.4 Remote payload Loopback

The Remote Payload Loopback is able to be activated and deactivated through EOC via CID interfaces, and is set up inside STU-C/STU-R as close as possible to the network side interfaces. The received signal is sent to network side interface. For example, if Remote Payload Loopback is activated at STU-C, the direction of Remote loopback would be like (D) in figure 2.4

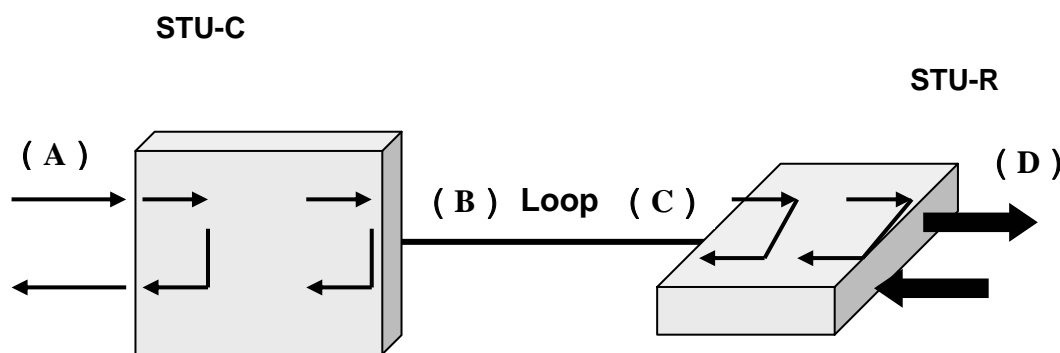

Figure 2.4 Remote payload Loopback

When any of these modes is activated, the loopback path causes the system operation to be disrupted. In particular, the Local SHDSL Loopback path opens the line, causing the system to lose synchronization. Once this loopback is deactivated, the system will reinitialize.

Chapter 3: APPLICATIONS

Dynamix Promotions Limited DYNAMIX 3000 offers several interface options to customers. The interface options help service providers target customer applications, such as synchronous E1/FE1, V.35, and Ethernet. In regulated environments, these products quickly solve the challenges of connecting many subscribers at high data rates. In unregulated environments, these products bring Internet, Intranet and other new services to campus and ISP markets. The following examples illustrate the variety of applications served by the DYNAMIX 3000 SHDSL access system. These configurations are but a sampling of the many combinations of interface modules. DYNAMIX 3000 access system interface options are continually being added and enhanced in order to provide high-speed WAN access to all telecommunications and data communications environments.

3.1 Far Reach Single Pair E1 or T1

The DYNAMIX 3000 (G.703 or T1 interface) products replace a four-wire transmission system, effectively doubling the utilization of the copper loop while extending the reach from below 9,000 feet to beyond 11,000 feet. A configuration is shown in (figure 3.1).

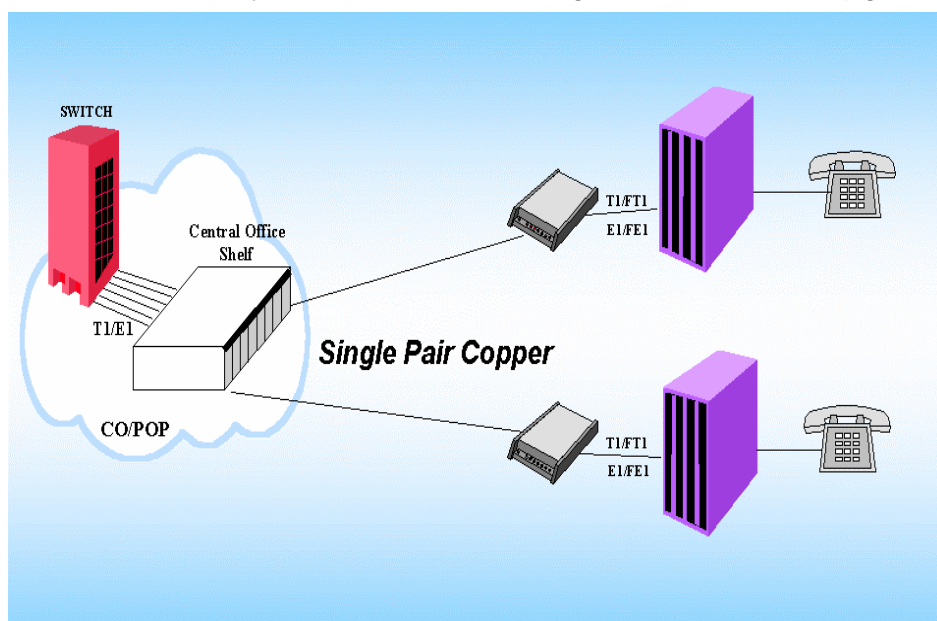

Figure 3.1 DYNAMIX 3000 E1, T1 replaces four wires with two wire systems. The E1 (G.703) or T1 interface provides standard data rate wherever E1 or Fractional E1, also T1 or Fractional T1, service is deployed or planned.

3.2 Fast Synchronous Interfaces

The DYNAMIX 3000 provides V.35 fast synchronous interface. A M34F, V.35 connector for connection to the selected synchronous interface is accessible from the back of the

Dynamix 3000 G.SHDSL TDM Based Rack

Bridged Ethernet, G.703 E1, DataCom V.35, X.21, RS-530, & RS-449 over SHDSL unit.

These V.35 interface modules facilitate new applications such as teleconferencing and commuting. The V.35 interface can be mixed with E1 or Fractional E1 interfaces for end-to-end transmission. Typical applications include MPEG quality video, video conferencing, and telecommuting and fast file transfer.

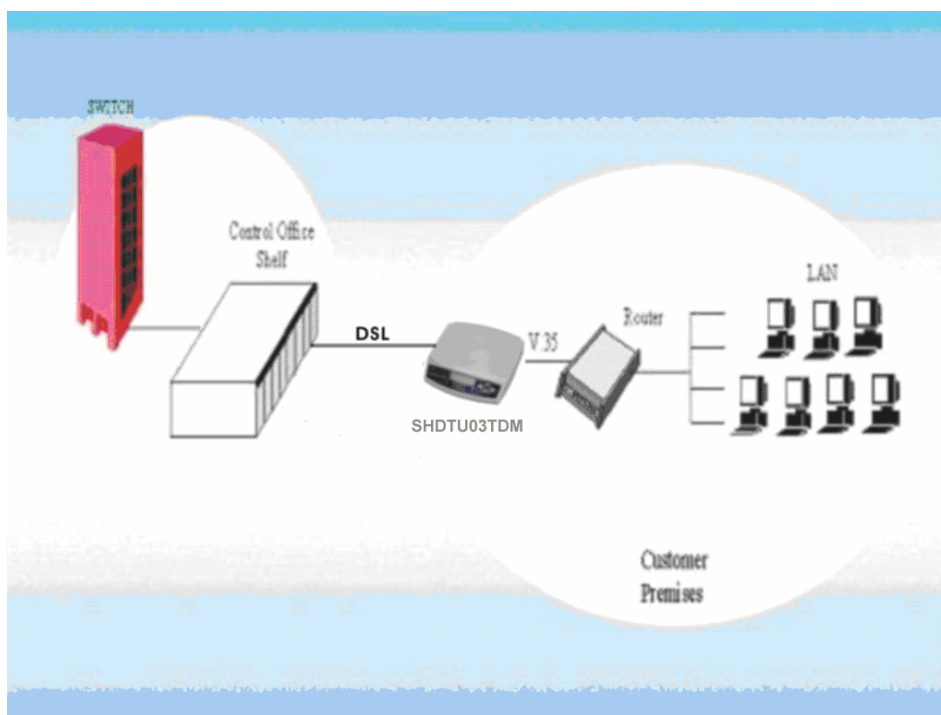

Figure 3.2 V.35 access with DYNAMIX 3000

3.3 Selectable Data Rates

DYNAMIX 3000 interfaces allow software selectable data rates at selected Fractional E1 rates set from the designated central office unit. The DYNAMIX 3000 V.35 module can be programmed for numerous Fractional E1 rates or set to automatically adjust to the fastest available rate.

Appropriate applications include programmable frame relay, channelized E1 service to PBX, bandwidth on demand for teleconferencing, distributed instruction, and Internet accesses.

3.4 Packet Interface: Ethernet

Ethernet access is provided as a remote Ethernet bridge (standard 802.3). A single workstation can directly connect the DYNAMIX 3000 Ethernet port to a personal computer. Alternately, the DYNAMIX 3000 Ethernet port can be interfaced to an Ethernet LAN and used as a multiple-user remote Ethernet bridge as shown in (Figure3.3)

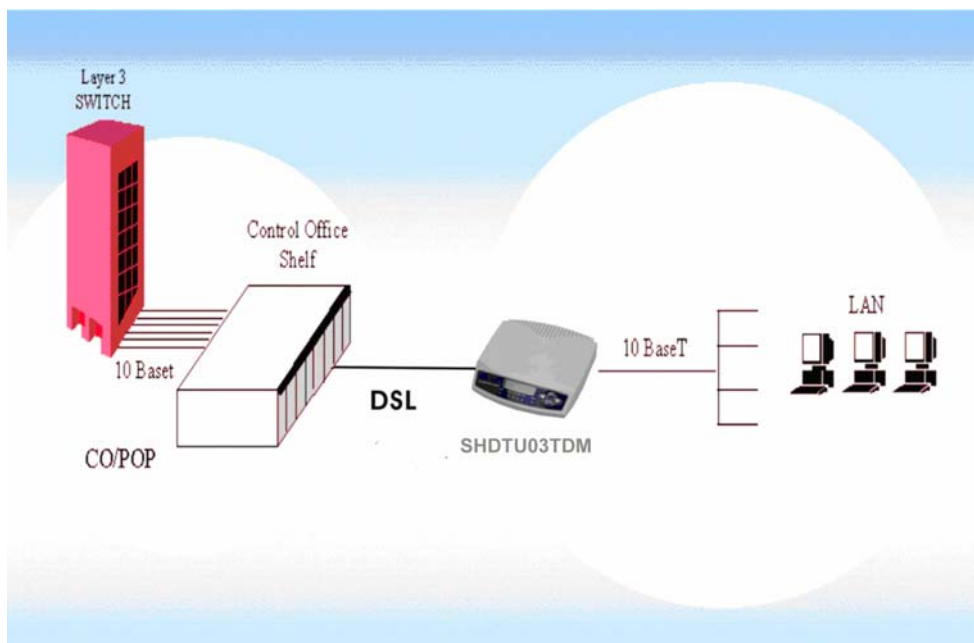

Figure 3.3 LAN access with a DYNAMIX 3000 remote Ethernet bridge
Applications for remote Ethernet connectivity are as numerous as the use of business systems and as ubiquitous as the prevalence of LAN environments. Examples include Internet Service Providers, corporate campus networks, remote computing, and video services.

Chapter 4: INSTALLATION

4.1 General

The following section will help you to understand how to install the DYNAMIX 3000 shelf access system. Understanding these topics will definitely make you knowing the DYNAMIX 3000 better.

4.2 Unpacking your DYNAMIX 3000

4.2.1 Tools Needed

The following items are needed for installing the shelf type DYNAMIX 3000

- Flat-blade screwdriver
- Phillips screwdriver
- Flat-nose pliers
- Wire-wrap/D-wrap tool
- Multimeter

4.2.2 Unpacking

Warning: When handling cards, use local office procedures regarding electrostatic discharge (ESD), including but not limited to the following:

Use grounded wrist straps connected to equipment frame ground when handling cards.

Store cards only in antistatic packaging provided by the factory.

Depending upon the number of units and spares you ordered, your shipment may consist of one or more boxes containing the following materials:

One DYNAMIX 3000 shelf unit.

One MIU card

Line Card Units (STU) with interface modules

This document.

Any other accessories requested at time of ordering.

Check the contents of the package and inspect the unit for any signs of damage. Report any damage to the carrier or contact Dynamix Promotions Limited Corporation's customer service representative. Retain all packing material for future shipment.

4.3 Shelf Installation

The shelf can be installed in a standard 19-inch or 23-inch rack, by using the mounting brackets provided.

Mount the shelf on the rack using the large screws provided.

Follows the following procedures to connect and wire the system

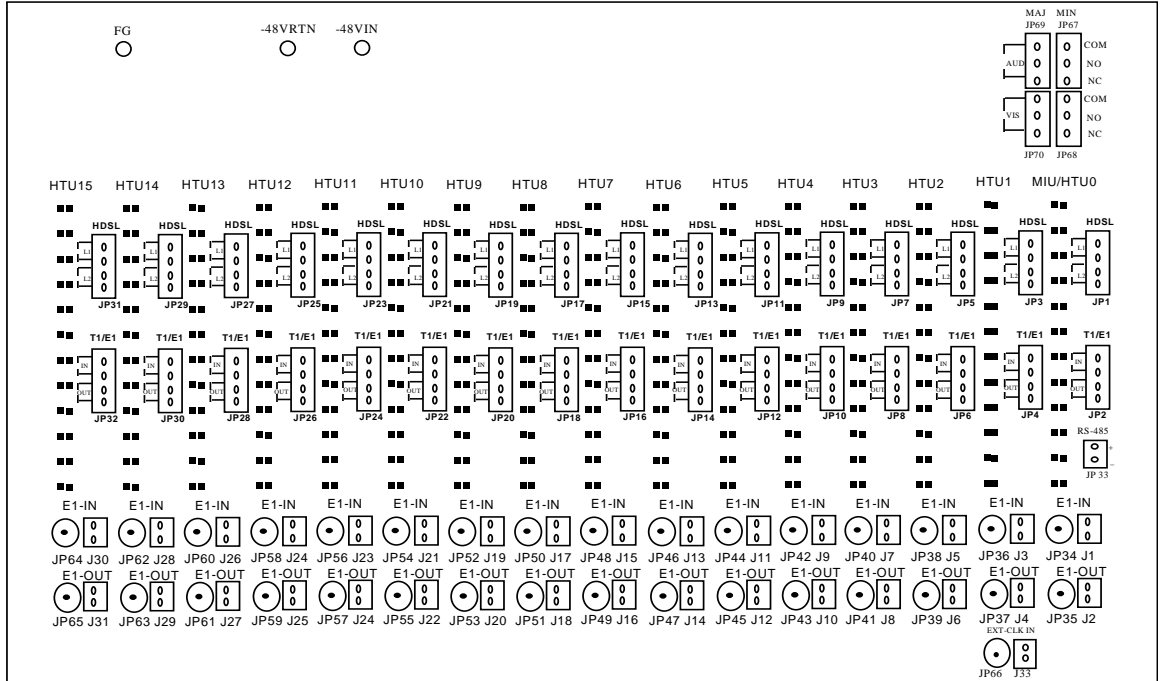

Figure 4.1 Rear view of DYNAMIX 3000 Shelf

4.3.1 Power Connection

Use the following procedures to connect the office power to the backplane of the CAPSPAN5000 shelf

- (1) Power off the voltage supply connection. Caution is needed since there may be dangerous levels of voltage and current present.
- (2) Use 16 AWG stranded wire to connect office battery supply leads from the fuse panel on the equipment rack to the terminal -48VIN of A POWER or B POWER or both (J34) A and B on the backplane.
- (3) Use 16 AWG stranded wire to connect RTN leads from the fuse panel on the equipment rack to the terminals -48VRTN of A POWER or B POWER or both (J34) A and B on the backplane.
- (4) Check the battery and ground on the inputs to ensure that there are no short circuit between -48VIN and -48VRTN.
- (5) Power on the voltage supply connection.
- (6) Use a multimeter to verify that the input voltage level is between -36 and -72 VDC. CAPSPAN5000 uses -48 VDC for system power and the allowable range is from -36 to -72 VDC.

Dynamix 3000 G.SHDSL TDM Based Rack
Bridged Ethernet, G.703 E1, DataCom V.35, X.21, RS-530, & RS-449 over SHDSL

4.3.2 Alarm Connection

The office alarms' connectors on the CAPSPAN 5000 Shelf backplane contain three types of pins (NC, C and NO) for visual MINOR/MAJOR alarm (JP68/ JP70) and audible MINOR/MAJOR alarm (JP67/JP69). The alarm contacts are NC (normally closed) or NO (normally open) connections, with reference to the C (common).

Note: If an alarm condition or loss of dc power, the system closes the circuit between the NO and C terminals, or opens the circuit between the NC and C terminals. The input tolerance of alarm circuit is 120V, 1A.

4.3.3 SHDSL Loop Connection

For each DYNAMIX 3000 STU provides front-access RJ-45 loop connection interface. Appendix A shows the pin assignment used. On some models, rear wire wrap can be used for loop connection using L1 of the pins labeled HDSL.

4.4 MIU and Line Card (STU) Installation

When you complete the installation of DYNAMIX 3000 shelf, you can start the MIU and STU installation. It will be recommended to start MIU installation at first. The DYNAMIX 3000 shelf-type is front-access design, so it is very easy to install the MIU and the STU.

4.4.1 MIU Functional Description

Figure 4.3 displays the front-view of the SIU.

The standard MIU module provides the menu-driven RS-232 interface to control the DYNAMIX 3000.

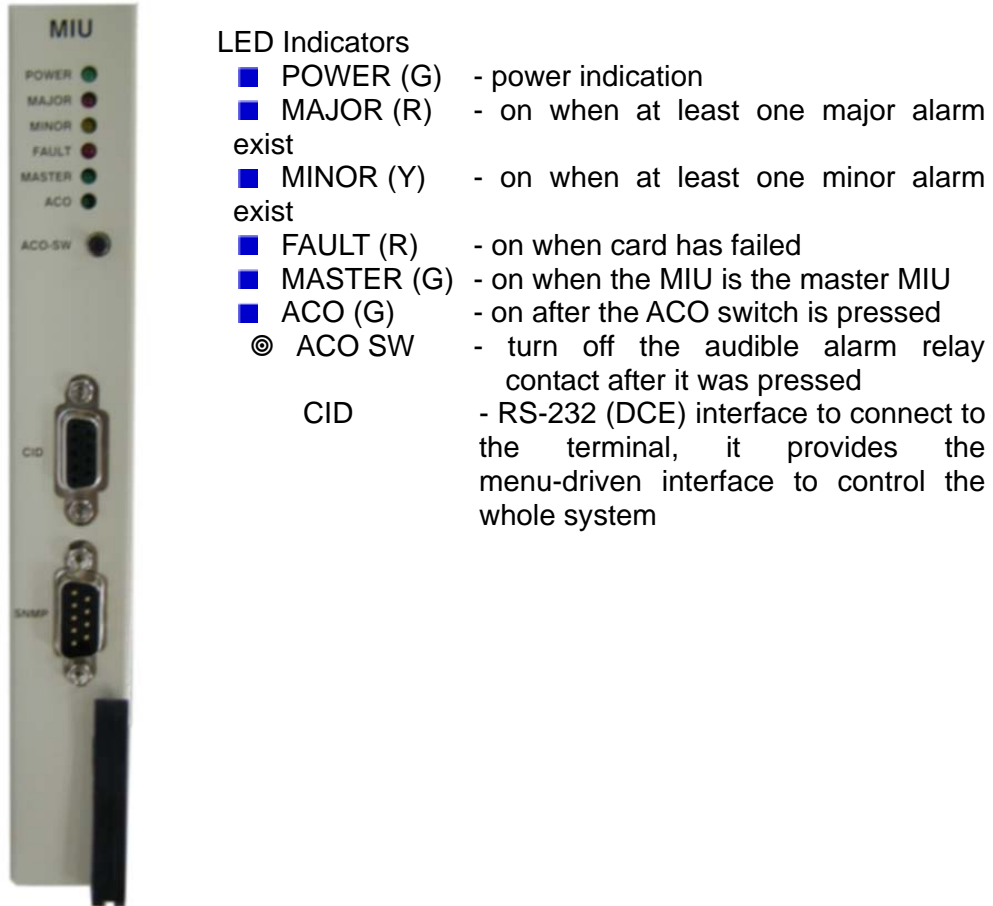

- LED Indicators**
- POWER (G) - power indication
 - MAJOR (R) - on when at least one major alarm exist
 - MINOR (Y) - on when at least one minor alarm exist
 - FAULT (R) - on when card has failed
 - MASTER (G) - on when the MIU is the master MIU
 - ACO (G) - on after the ACO switch is pressed
 - Ⓞ ACO SW - turn off the audible alarm relay contact after it was pressed
- CID** - RS-232 (DCE) interface to connect to the terminal, it provides the menu-driven interface to control the whole system

Figure 4.3 Front View of the MIU

4.4.1.1 MIU Installation Procedure

- (1). For general application, the MIU ID does not need to be changed. The ID is changed by modify the switch labeled S1 on the MIU PCB. The factory default setting is zero, 0.
- (2). Insert the MIU into the slot labeled "SLOT 0". All the LEDs in the MIU will turn on to indicate that system initialization is in process. When this is completed, the LEDs will display the current status of the managed shelf.
- (3). Connect the cable between your PC and CID port on the front panel of the MIU. The CID port is configured as DCE. The connection for such link is given below:

Male (9/25 pin)	Wiring	Male (9/25 pin)
TD (2/3)	—————	TD (2/3)
RD (3/2)	—————	RD (3/2)

Dynamix 3000 G.SHDSL TDM Based Rack
Bridged Ethernet, G.703 E1, DataCom V.35, X.21, RS-530, & RS-449 over SHDSL

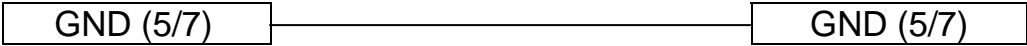

(4). The CAPSPAN5000 can be remote controlled through a modem connection to the MIU's CID. In order to use such connection, the null modem is needed to bridge the connection between modem's serial port and MIU's CID port. The connection for such null modem is suggested below:

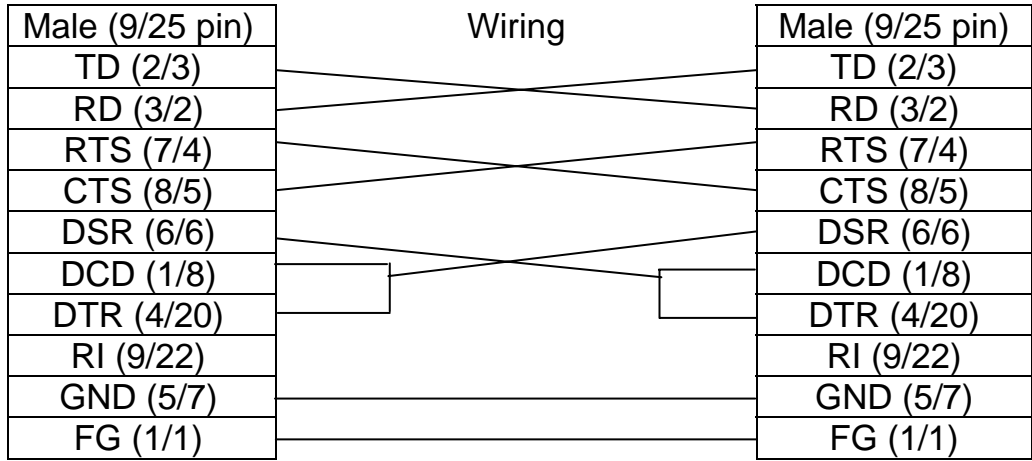

4.5 STU Installation

To install the STU, there requires several I/O cables, which you will have to supply. The I/O cables should be long enough to connect your DTE equipment and the DSL link to the specified jacks on the front panel of the STU. All of the cables are identified below:

Link cable. Connects your DTE equipment to the STU. The connector on the STU end of the cable must be depends upon the type of mating connector on your equipment. The pin assignments for these connectors appear in Appendix A. EIA-530 to V.35 and EIA-530 to RS-449 conversion cable can be ordered from DYNAMIX PROMOTIONS LIMITED at the time of ordering.

Line cables. Line cables connect the DSL line to the STU. The SHDSL loop connection uses pins 4 and 5 of the 8 pins RJ-45 jack. One can use the optional RJ45 to RJ11 cable line cable supplied for connection to telephone jack.

4.5.1 Installation Procedure

(1). Place the DTE equipment within 5 meters (15 feet) of the DYNAMIX 3000. The actual distance depends on how long the link cable is.

(2). Connect and install the DSL line cable to the STU's LOOP jack. The 8 pins LOOP RJ-45 jack uses pins 4 and 5 for loop connection. As an optional accessory, DYNAMIX PROMOTIONS LIMITED can include a DSL line cable, which has RJ-45 connector on one side and RJ-11 connector on the other side. Appendix A lists the pin assignments for this cable.

Dynamix 3000 G.SHDSL TDM Based Rack
Bridged Ethernet, G.703 E1, DataCom V.35, X.21, RS-530, & RS-449 over SHDSL

(3). Attach the end of the link cable to the interface port or conversion cable of the STU. This connector is M34F for a V.35 interface, DB-25 for EIA-530 interface, DB-37 for RS-449 interface and RJ-45 for an Ethernet interface.

The DYNAMIX 3000 STU goes through an initialization and startup process; during this time, the LEDs will flash to indicate that system initialization is in process. When this is completed, the front panel LED displays its current status.

For detailed information about the dip switches and push button on the 10/100 BaseT interface, please check Appendix C.

4.6 LED Descriptions

The SHDSL unit has six LEDs (light emitting diode) and their meanings and actions are listed in the table below:

PWR	On	It indicates that the unit has normal power
	Off	The unit has no power
DSL	On	Loop has synchronized
	Off	Loop has not synchronized
	Flash	Loop has achieved handshake
LNK	On	User interface is present
	Off	User interface is not present
TST	On	Performing the maintenance tests
	Flash	The maintenance test is being performed on the other unit
	Off	Not performing the maintenance tests
CPE	On	The unit is customer premises equipment
	Off	The unit is central office equipment
ALM	On	The system has alarm
	Off	The system is operating normally
	Flash	Remote Alarm

Chapter 5: MIU/CID Configuration/Operation

This chapter describes how to use an external terminal or PC to configure, maintain and administrate the DYNAMIX 3000 system via the MIU's CID port.

5.1 Terminal Operation

This chapter describes how to use an external terminal or PC to configure, maintain and administrate the DYNAMIX 3000 system via the MIU's CID port.

5.2 Screen Definition

The MIU/CID provides two kinds of the screen. The first screen is menu-driven and the other is a cursor-control screen. The menu-driven screen guides the user to select the desired function. The functions are separated into functional groups. Figure 5.1 displays an example of the menu-driven screen.

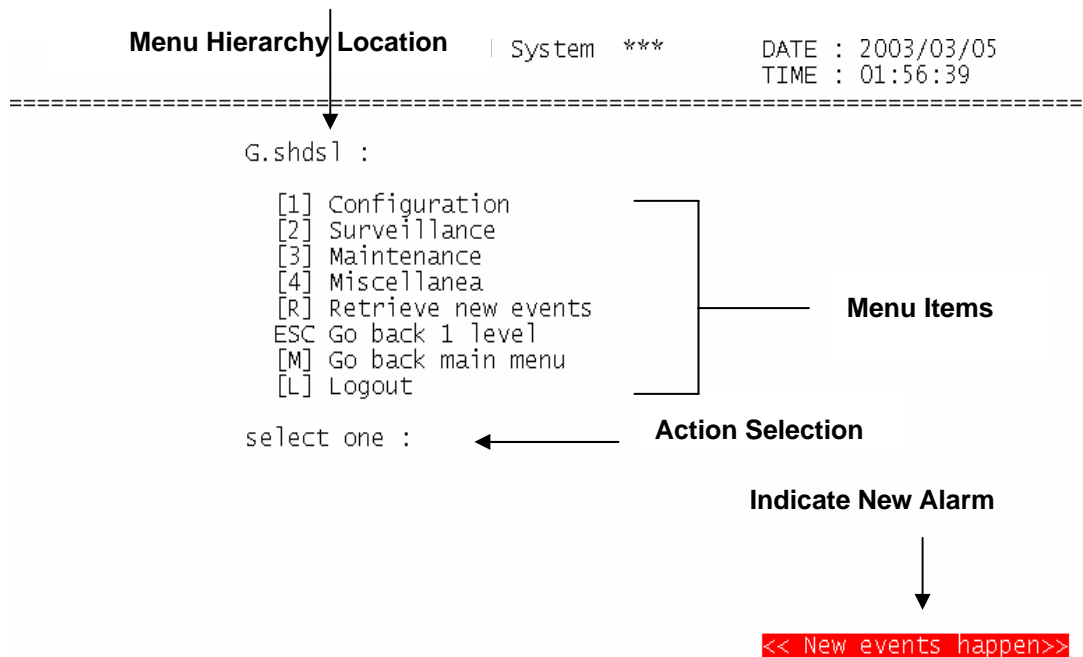

Figure 5.1 the Menu-Driven Screen

As shown in Figure 5.1, the operator can press the specified character listed in the [] bracket to select the desired functional groups. There are 5 functional groups. They are configuration, surveillance, maintenance, miscellanea, retrieve new events. Each of the functional groups is explained in more detail in the following sections regarding its mode of operation and parameters available. When there is any new event occurring, the << **New events happen** >> icon in the lower right hand corner of the screen will appear and

Dynamix 3000 G.SHDSL TDM Based Rack

Bridged Ethernet, G.703 E1, DataCom V.35, X.21, RS-530, & RS-449 over SHDSL

flash to attract operator's attention. Press "R" while in the main menu can retrieve new events.

User may enter the cursor-control screen if the selected functional group can be displayed and controlled in one screen. Figure 5.2 displays an example of the cursor-control screen.

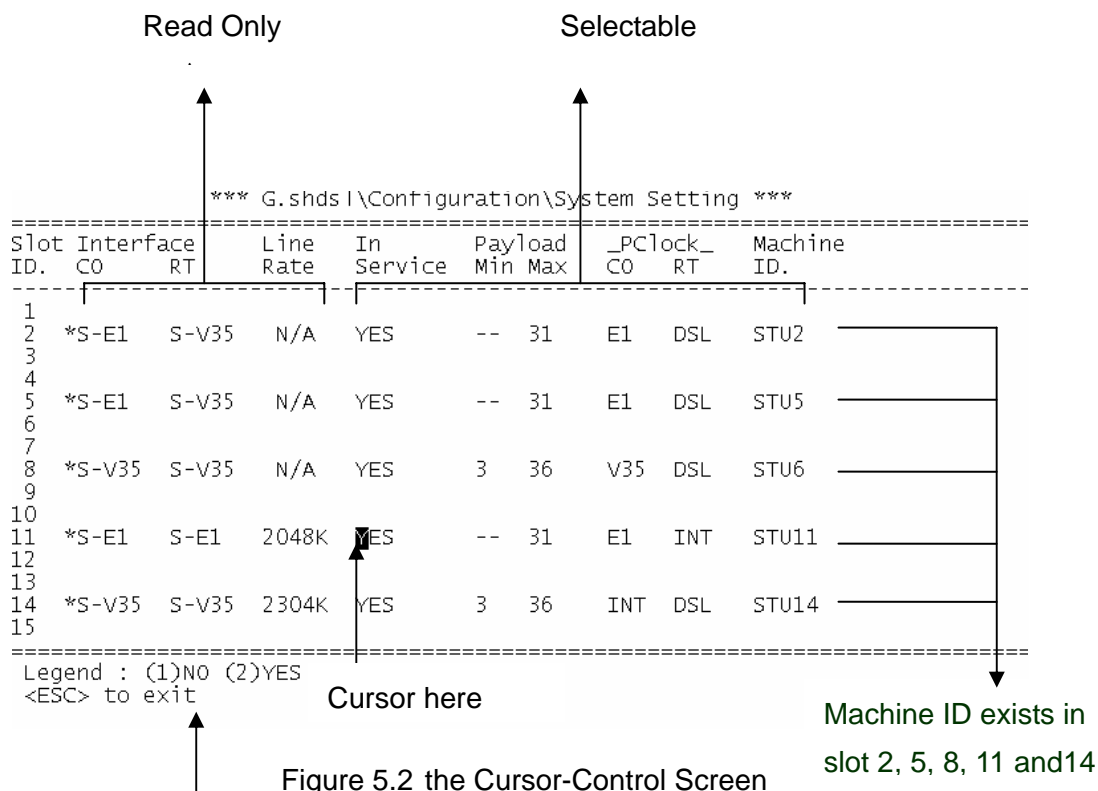

Figure 5.2 the Cursor-Control Screen

Legal value to select in the Field the cursor resides

In the above cursor-control screen, you can see the following information.

- The shelf is equipped with 5 STUs in slot 2,5,8,11 and slot 14 respectively.
- The parameters in the screen can be divided into read-only area and selectable area.
- The values displayed in the read-only area indicate current status or configuration of the specified link. User cannot change the value in this area (i.e.: cursor can not move in to this area). In this example, the Interface-CO, Interface-RT, and Line Rate column belong to the read-only area. As shown in Figure 5.2, the interface of the STU-C appearing in slot 11 is E1 and the interface module at RT is E1. The DSL line rate for slot 11 is 2048K.
- In addition to the parameters listed in the read-only area, the other parameters belong to the selectable area. All the value display in the selectable area indicates its current setting of the specified parameter. User can use cursor "←", "↑", "→" and "↓" to move the cursor to the desired location to change its content. Where the cursor is at, the Legend field in the lower left hand corner of the screen displays the legal options to select. User

Dynamix 3000 G.SHDSL TDM Based Rack

Bridged Ethernet, G.703 E1, DataCom V.35, X.21, RS-530, & RS-449 over SHDSL

may change its current setting by selecting the item listed in the legend field. In this example, cursor stays at the "In Service" column, Slot 11 position. Its current value is YES. You can see its legal values are (1) No and (2) YES in Legend Field. Just type "1" to set the STU in slot 11 to out of service state. Sometimes, only <CR> is displayed in the legend field, it means that the operator has to press <CR> to see the complete value in a new screen.

- press <ESC> to exit this screen.

5.3 Parameter Description of this manual

In the following sections, the table shown below is used to describe the parameters displayed in the cursor control screen. The fields in the table are explained below.

Parameter Name	R/W	Interface Type	Legal Value	Description
----------------	-----	----------------	-------------	-------------

Parameter Name :

The parameter name field contains the parameter columns of the cursor control screen. For example, rows 3 and 4 of Figure 5.2, Interface-CO, Interface-RT, and etc, are all different kinds of the parameter name.

R/W:

This field indicates whether the parameter is operator selectable. If the value is "RO", it means that this parameter belongs to the Read-Only area and cannot be modified. If the value is "R/W" or "WO" it means that this parameter belong to the selectable area and can be modified according to the parameter listed in the legend field.

Interface Type:

The interface types available are S-V35, S-E1, S-T1, S-ETH, and ALL. M-V35 interface settings are applicable to V.35, EIA-530 and RS-449 interfaces. This field describes the parameters specific to certain or all interface types. The value of "ALL" means this parameter applies to all interfaces that DYNAMIX 3000 provides.

Legal Value

This field describes the legal value that can be applied to this parameter. This is the same selections display in the Legend field. Only the parameters in the selectable area provide this field.

Description

Describes the parameter in detail.

5.4 Main Menu of the CID

Following is the main menu structure of the DYNAMIX 3000 CID

```
*** G.shdsl Central Control System ***      DATE : 2003/03/05  
                                           TIME : 01:56:39
```

=====

```
G.shdsl :  
  [1] Configuration  
  [2] Surveillance  
  [3] Maintenance  
  [4] Miscellanea  
  [R] Retrieve new events  
  ESC Go back 1 level  
  [M] Go back main menu  
  [L] Logout
```

select one :

<< New events happen >>

In order to bring up the main menu, press the “M” key in any menu, or press the “Esc” key until the screen listed above shows. If the terminal screen is unreadable, presses the “Esc” key repeatedly to bring up the main menu. If all efforts fail, make sure the proper cable has been used and the supervisory port parameter (9600, No parity, 1 stop bit and 8 data bits) settings match the terminal settings.

Note: Press the “Esc” key for returning to previous page.

5.5 Configuration Menu

Press "1" in the main menu and the G.SHDSL/Configuration screen appears.

```
*** G.shdsl Central Control System ***          DATE : 2003/03/05
                                                TIME : 02:09:15
```

```
=====
G.shdsl\Configuration :

[1] System Setting
[2] E1-T1 Interface Setting
[3] DTE Interface Setting
[4] DSL Interface Setting
[5] E1-T1 PM Threshold Setting
[6] DSL PM Threshold Setting
[7] Recall Configuration
[8] Store Current Configuration
[R] Retrieve new events
ESC Go back 1 level
[M] Go back main menu
[L] Logout
```

select one :

<< New events happen >>

The G.SHDSL\Configuration screen consists of 8 sub-functional groups. How to configure the DYNAMIX 3000 system is described in the following sections.

5.5.1 System Setting

Press "1" to select System Setting functional group in the G.SHDSL\Configuration screen and the following cursor control menu appears.

```
*** G.shdsl\Configuration\System Setting ***
```

```
=====
```

Slot ID.	Interface CO	RT	Line Rate	In Service	Payload Min	Max	_PClock_ CO	RT	Machine ID.
1									
2	*S-E1	S-V35	N/A	YES	--	31	E1	DSL	STU2
3									
4									
5	*S-E1	S-V35	N/A	YES	--	31	E1	DSL	STU5
6									
7									
8	*S-V35	S-V35	N/A	YES	3	36	V35	DSL	STU6
9									
10									
11	*S-E1	S-E1	2048K	YES	--	31	E1	INT	STU11
12									
13									
14	*S-V35	S-V35	2304K	YES	3	36	INT	DSL	STU14
15									

```
=====
Legend : (1)NO (2)YES
<ESC> to exit
```

Dynamix 3000 G.SHDSL TDM Based Rack
Bridged Ethernet, G.703 E1, DataCom V.35, X.21, RS-530, & RS-449 over SHDSL

Table 5.1 System Setting Parameter Descriptions

Parameter Name	R/W	Interface Type	Legal Value	Description
Interface-CO	RO	-	-	Indicate current CO side interface type.
Interface-RT	RO	-	-	Indicate current RT side interface type.
Line Rate	RO	-	(M*64K+N*8K) bps,	The connected DSL loop line rate. M= 2, 4, 6, 8, 12, 16, 24, 32, 36. N= 1 【T1(CO) toT1(RT) 】 N=0 【other status】。 S-T1 max transmission rate, M=24 S-E1 max transmission rate, M=32 S-V35 max transmission rate, M=36 S-ETH max transmission rate, M=36
In Service	R/W	All	(1) NO (2) YES	When set to NO (Out-Of-Service), the alarms and events related to this SHDSL link will be filtered out. It is useful to set a link to NO, when a link is under maintenance so that no false alarms are reported to management center.
Payload Min/Max	R/W	S-E1 S-V35 S-ETH S-T1	2-31 3-36 3-36 3-24	Show or configure the current transmission rate that the user interface is using and its legal value is N*64K, where N is from 3 to 36. For E1 interface , Max rate is 31 x 64Kb/s. For T1 , Max rate reaches 24 x 64Kb/s. For E1 or T1 , press “CR” can change Payload rate ; Refer to Section 5.5.1.1 for detail procedure. For V.35 (EAI-530, RS-449) or Ethernet , press “CR” and key-in the value (from 3~36) to change the payload rate. When CO is E1 or T1 , it only provides Max Payload function , not supporting rate adaptive.
PClock-CO	R/W	All	(1) INT (2) I/F	Select the clock source for the SHDSL-CO side. INT means internally generated clock and I/F means clock source is from E1, T1 or DTE depends on the interface type.
PClock-RT	R/W	All	(1) DSL (2) I/F	Same as PClock-CO settings, except that there is no INT selection. DSL means the clock is recovered from the DSL link.
Machine ID	R/W	All		press<CR> to change Machine ID

**Dynamix 3000 G.SHDSL TDM Based Rack
Bridged Ethernet, G.703 E1, DataCom V.35, X.21, RS-530, & RS-449 over SHDSL**

5.5.2 E1-T1 Interface Setting

After “2” is pressed to select E1-T1 Interface Setting functional group in the G. SHDSL\Configuration screen, the following menu screen appears.

```

*** G.shdsl\Configuration\E1-T1 Interface Setting ***
=====
Slot Interface      Frame   Line Code   _LBO_
ID.  CO    RT      Format    CO    RT      CO    RT
-----
 1
 2  *S-E1  S-V35  FAS+CRC  HDB3  --    --    --
 3
 4
 5  *S-E1  S-V35  FAS+CRC  HDB3  --    --    --
 6
 7
 8  *S-V35  S-V35  --        --    --    --    --
 9
10
11  *S-E1  S-E1   FAS+CRC  HDB3  HDB3  --    --
12
13
14  *S-V35  S-V35  --        --    --    --    --
15
=====
Legend : (1)UNFRAME (2)FAS+CRC (3)FAS
<ESC> to exit

```

Table 5-2 E1 and T1 Interface Setting Parameter Descriptions

Parameter Name	R/W	Interface Type	Legal Value	Description
Interface-CO	RO	-	-	Indicate current CO side interface.
Interface-RT	RO	-	-	Indicate current RT side interface.
Frame Format	R/W	S-E1	(1) UNFRAME (2) FAS+CRC (3) FAS	(1) Means do not check the input E1 data; just pass it to the DSL link. (2) FAS plus CRC checking (3) FAS (CRC off)
		S-T1	(1) UNFRAME (2) ESF (3) SF	(1) Means do not check the input E1 data; just pass it to the DSL link. (2) Extended Super Frame. (3) Super Frame (AT&T D4 format)
Line Code-CO	R/W	S-E1	(1) HDB3	E1 line code setting.
		S-T1	(1) AMI (2) B8ZS	T1 line code setting.
Line Code-RT	R/W	S-E1	(1) HDB3	E1 line code setting.
		S-T1	(1) AMI (2) B8ZS	T1 line code setting.
LBO-CO	R/W	S-T1	(1) 0 ~ 132 ft (2) 133 ~ 265 ft (3) 266 ~ 398 ft (4) 399 ~ 532 ft (5) 533 ~ 655 ft	T1 LBO (Line Built Out)(i.e. equalizer) setting. Not supported for E1 interface.
LBO-RT	R/W	S-T1	(1) 0 ~ 132 ft (2) 133 ~ 265 ft (3) 266 ~ 398 ft (4) 399 ~ 532 ft (5) 533 ~ 655 ft	T1 LBO (Line Built Out) (i.e. equalizer) setting. Not supported for E1 interface.

**Dynamix 3000 G.SHDSL TDM Based Rack
Bridged Ethernet, G.703 E1, DataCom V.35, X.21, RS-530, & RS-449 over SHDSL**

5.5.3 DTE Interface Setting

After “3” is pressed to select DTE Interface Setting functional group in the G.SHDSL\Configuration screen, the following menu screen appears.

```

*** G.shdsl\configuration\DTE Interface Setting ***
=====
Slot Interface      Data Polarity      _____RTS_____
ID.  CO      RT      CO      RT      CO      RT
-----
1
2  *S-E1    S-V35  █-      NORMAL  --      NORMAL
3
4
5  *S-E1    S-V35  --      NORMAL  --      NORMAL
6
7
8  *S-V35    S-V35  NORMAL  NORMAL  NORMAL  NORMAL
9
10
11 *S-E1     S-E1   --      --      --      --
12
13
14 *S-V35    S-V35  NORMAL  NORMAL  NORMAL  NORMAL
15
=====
Legend : V.35 only
<ESC> to exit

```

Table 5-3 DTE Interface Setting Parameter Descriptions

Parameter Name	R/W	Interface Type	Legal Value	Description
Interface-CO	RO	-	-	Indicate current CO side interface.
Interface-RT	RO	-	-	Indicate current RT side interface.
Data Polarity-CO	R/W	S-V35 S-ETH	(1) NORMAL (2) INVERTED	When NORMAL is selected, data polarity is transmitted the same as received and when INVERTED , transmitted data is the inverse of data received from DTE port.
Data Polarity-RT	R/W	S-V35 S-ETH	(1) NORMAL (2) INVERTED	Same as Data Polarity-CO
RTS-CO	R/W	S-V35 S-ETH	(1) PERMANENT (2) NORMAL	The input RTS signal is used to detect if connection to user equipment is correct. When PERMANENT is selected, the RTS signal is considered to exist always. When NORMAL is selected, the RTS signal is used to enable or disable idle code transmission when RTS is off or on, respectively.
RTS-RT	R/W	S-V35 S-ETH	(1)PERMANENT (2) NORMAL	Same as RTS-CO

5.5.4 DSL Interface Setting

After “4” is pressed to select DSL Interface Setting functional group in the G.SHDSL\Configuration screen, the following menu screen appears.

```

*** G.shdsl\Configuration\DSL Interface Setting ***
=====
Slot Interface      Worst Case  Line   Power   Power  Backoff
ID.  CO      RT      Target SNR  Probe  Backoff  CO      RT
-----
1
2  *S-E1   S-V35   0        ON     Default  0      0
3
4
5  *S-E1   S-V35   0        ON     Default  0      0
6
7
8  *S-V35  S-V35   0        ON     Default  0      0
9
10
11 *S-E1   S-E1    0        ON     Default  0      0
12
13
14 *S-V35  S-V35   0        ON     Default  0      0
15
=====
Legend : press <CR> to enter a value, range is [-10,21]dB
<ESC> to exit

```

Table 5-3 DTE Interface Setting Parameter Descriptions

Parameter Name	R/W	Interface Type	Legal Value	Description
Interface-CO	RO	-	-	Indicate current CO side interface.
Interface-RT	RO	-	-	Indicate current RT side interface.
Worst Case Target SNR	R/W	All	-10~21 dB	Configure Worst Case Target SNR range from -10 to 21
Line probe	R/W	All	(1) OFF (2) ON	Enable or disable Line Probe function
Power Backoff	R/W	All	(1) Default (2) Enhanced	(1)refer to Power Backoff of IETF RFC3276 (2)manual adjusting Power Backoff value
Power CO	R/W	All	0~30 dB	When Power Backoff is configured as Enhanced , press <CR> could configure the range of Power CO (0~30 dB)
Power Backoff RT	R/W	All	0~30 dB	When Power Backoff is configured as Enhanced , press <CR> could configure the range of Power RT (0~30 dB)

**Dynamix 3000 G.SHDSL TDM Based Rack
Bridged Ethernet, G.703 E1, DataCom V.35, X.21, RS-530, & RS-449 over SHDSL**

5.5.5 E1-T1 PM Threshold Setting

When “5” is pressed to select ET1 PM Threshold Setting functional group in the G.SSDSL\Configuration screen, the following menu screen appears. ET1 PM threshold is used as an alarm threshold for the 15-minute and 1 day PM count registers. When the PM counter’s value is greater than the threshold value, an alarm will be generated. For detailed information about the alarm types generated please refer to Appendix B.

```

*** G.shdsl\Configuration\ET1 PM Threshold Setting ***
=====
Slot Interface      15 min      1 day
ID.  CO   RT   ES   SES   UAS   ES   SES   UAS
-----
1
2  *S-E1  S-V35  0  --  0  --  0  --  0  --  0  --
3
4
5  *S-E1  S-V35  0  --  0  --  0  --  0  --  0  --
6
7
8  *S-V35  S-V35  --  --  --  --  --  --  --  --  --  --
9
10
11 *S-E1  S-E1   0  0  0  0  0  0  0  0  0  0  0
12
13
14 *S-V35  S-V35  --  --  --  --  --  --  --  --  --  --
15
=====
Legend : press <CR> to enter threshold value, range is [0,900]
<ESC> to exit

```

Table 5-4 E1-T1 PM Threshold Setting parameter

Note: Legal Value=0 means threshold alarm disable

Parameter Name	R/W	Interface Type	Legal Value	Description
Interface-CO	RO	-	-	Indicate current CO side interface.
Interface-RT	RO	-	-	Indicate current RT side interface.
15 min E1-T1 ES-CO	R/W	S-E1 S-T1	0-900	Set the CO threshold of E1 or T1 interface 15 minutes Error Second.
15 min E1-T1 ES-RT	R/W	S-E1 S-T1	0-900	Set the RT threshold of E1 or T1 interface 15 minutes Error Second.
15 min E1-T1 SES-CO	R/W	S-E1 S-T1	0-900	Set the CO threshold of E1 or T1 interface 15 minutes Severe Error Second.
15 min E1-T1 SES-RT	R/W	S-E1 S-T1	0-900	Set the RT threshold of E1 or T1 interface 15 minutes Severe Error Second.
15 min E1-T1 UAS-CO	R/W	S-E1 S-T1	0-900	Set the CO threshold of E1 or T1 interface 15 minutes Unavailable Second.
15 min E1-T1 UAS-RT	R/W	S-E1 S-T1	0-900	Set the RT threshold of E1 or T1 interface 15 minutes Unavailable Second.
1 Day E1-T1 ES-CO	R/W	S-E1 S-T1	0-86400	Set the CO threshold of E1 or T1 interface 1 Day Error Second.
1 Day E1-T1 ES-RT	R/W	S-E1 S-T1	0-86400	Set the RT threshold of E1 or T1 interface 1 Day Error Second.
1 Day E1-T1 SES-CO	R/W	S-E1 S-T1	0-86400	Set the CO threshold of E1 or T1 interface 1 Day Severe Error Second.
1 Day E1-T1 SES-RT	R/W	S-E1 S-T1	0-86400	Set the RT threshold of E1 or T1 interface 1 Day Severe Error Second.
1 Day E1-T1 UAS-CO	R/W	S-E1 S-T1	0-86400	Set the CO threshold of E1 or T1 interface 1 Day Unavailable Second.
1 Day E1-T1 UAS-RT	R/W	S-E1 S-T1	0-86400	Set the RT threshold of E1 or T1 interface 1 Day Unavailable Second.

5.5.6 DSL PM Threshold Setting

When “6” is pressed to select DSL PM Threshold Setting functional group in the G.SSDSL\Configuration screen, the following menu screen appears. DSL PM threshold is used as an alarm threshold for the 15-minute and 1 day PM count registers. When the PM counter's value is greater than the threshold value, an alarm will be generated. For detailed information about the alarm types generated please refer to Appendix B.

```

*** G.shdsl\Configuration\DSL PM Threshold Setting ***
=====
Slot Interface      Loop SNR      - 15 min -      ----- 1 day -----
ID. CO      RT      Atten Margin  ES  SES  UAS  _ES_  _SES_  _UAS_
=====
1
2  *S-E1      S-V35      0      0      0  0  0      0      0      0
3
4
5  *S-T1      S-T1      0      0      0  0  0      0      0      0
6
7
8  *S-V35     S-V35     0      0      0  0  0      0      0      0
9
10
11 *S-E1      S-E1      0      0      0  0  0      0      0      0
12
13
14
15
=====
Legend : press <CR> to enter a Loop Attenuation threshold value, [0,127]dB
<ESC> to exit

```

Table 5-5 DSL PM Threshold Setting parameter

Parameter Name	R/W	Interface Type	Legal Value	Description
Interface-CO	RO	-	-	Indicate current CO side interface.
Interface-RT	RO	-	-	Indicate current RT side interface.
Loop Atten	R/W	V35 ETH	0-127 dB	Set Loop attenuation range Note: Legal Value=0 means alarm disable
SNR Margin	R/W	V35 ETH	0-15 dB	Set SNR Margin range Note: Legal Value=0 means alarm disable
15 min ES	R/W	V35 ETH	0-900	Set DSL PM 15 minutes Error Seconds threshold. Note: Legal Value=0 means PM alarm disable
15 min SES	R/W	V35 ETH	0-900	Set DSL PM 15minutes Severe Error Seconds threshold. Note: Legal Value=0 means PM alarm disable
15 min UAS	R/W	V35 ETH	0-900	Set DSL PM 15minutes Unavailable Seconds threshold. Note: Legal Value=0 means PM alarm disable
1 day ES	R/W	V35 ETH	0-86400	Set DSL PM 1 Day Error Seconds threshold. Note: Legal Value=0 means PM alarm disable
1 day SES	R/W	V35 ETH	0-86400	Set DSL PM 1 Day Severe Error Seconds threshold. Note: Legal Value=0 means PM alarm disable

**Dynamix 3000 G.SHDSL TDM Based Rack
Bridged Ethernet, G.703 E1, DataCom V.35, X.21, RS-530, & RS-449 over SHDSL**

1 day UAS	R/W	V35 ETH	0-86400	Set DSL PM 1 Day Unavailable Seconds threshold. Note: Legal Value=0 means PM alarm disable
-----------	-----	------------	---------	---

5.5.7 Recall configuration

When “7” is pressed to select Recall Configuration functional group in the G.SHDSL\Configuration screen, the following menu screen appears.

```

*** G.shdsl\Configuration\RECALL ***
=====
Slot Interface      Recall  Recall  Recall
ID.  CO    RT      Default Backup  Factory
-----
1
2  *S-E1  S-V35   <CR>   <CR>   <CR>
3
4
5  *S-E1  S-V35   <CR>   <CR>   <CR>
6
7
8  *S-V35  S-V35   <CR>   <CR>   <CR>
9
10
11 *S-E1   S-E1    <CR>   <CR>   <CR>
12
13
14 *S-V35  S-V35   <CR>   <CR>   <CR>
15
=====
Legend : press <CR> to activate recall operation
         <ESC> to exit

```

Table 5.6 Recall Configuration Parameter Descriptions

Parameter Name	R/W	Interface Type	Legal Value	Description
Interface-CO	RO	-	-	Indicate current CO side interface.
Interface-RT	RO	-	-	Indicate current RT side interface.
Recall Default	WO	All	<CR>	Set the configuration parameters to its default value, but unit role and interface will not be changed.
Recall Backup	WO	All	<CR>	Recall the configuration parameters to the value that was stored using backup.
Recall Factory	WO	All	<CR>	Recall the factory configuration.

5.5.8 Store Current Configuration

When “8” is pressed to select Store Current Configuration functional group in the G.SHDSL\Configuration screen, the following menu screen appears.

```

*** G.shdsl\Configuration\STORE ***
=====
Slot Interface      Activate
ID.  CO      RT      Store Operation
-----
 1
 2 *S-E1    S-V35    █<CR>
 3
 4
 5 *S-E1    S-V35    <CR>
 6
 7
 8 *S-V35    S-V35    <CR>
 9
10
11 *S-E1    S-E1     <CR>
12
13
14 *S-V35    S-V35    <CR>
15
=====
Legend : press <CR> to activate store operation
         <ESC> to exit

```

Table 5.7 Store Configuration Parameter Descriptions

Parameter Name	R/W	Interface Type	Legal Value	Description
Interface-CO	RO	-	-	Indicate current CO side interface.
Interface-RT	RO	-	-	Indicate current RT side interface.
Activate Store Operation	W	All	<CR>	Store the all the configuration parameters to backup memory.

5.6 Surveillance

When “2” in the main menu is pressed, the G.SHDSL\Surveillance screen appears and the operator is presented with more selections.

```

*** G.shdsl Central Control System ***          DATE : 2003/04/10
                                                TIME  : 14:27:01
=====
G.shdsl\Surveillance :

    [1] Retrieve Alarms
    [2] Retrieve Status
    [3] Retrieve PM
    [4] Retrieve DSL SNR & Loop Atten
    [5] Retrieve & Reset Event Logs
    [6] Retrieve Version
    [7] Reset PM Data
    ESC Go back 1 level
    [M] Go back main menu
    [L] Logout

select one : █

```

There are 7 function groups in the G.SHDSL\Surveillance screen. The following sections describe the function groups in more detail.

5.6.1 Retrieve Alarm

After pressing "1" to select Retrieve Alarms functional group in the G.SHDSL\Surveillance screen, the following cursor control menu shows.

```

*** G.shdsl\Surveillance\Retrieve Alarms ***
=====
Slot Interface
Id. CO RT select CO DSL RT CO RT CO DTE RT
=====
1
# 2 *S-E1 S-V35 <CR> LOSW -- LOS -- -- --
3
4
# 5 *S-E1 S-V35 <CR> LOSW -- LOS -- -- --
6
7
# 8 *S-V35 S-V35 <CR> LOSW -- -- -- LoDTE --
9
10
#11 *S-E1 S-E1 <CR> -- -- LOS -- -- --
12
13
#14 *S-V35 S-V35 <CR> -- -- -- -- LoDTE --
15
=====
Legend : [R] to read all alarms, <CR> to read current alarms in the slot
'#' indicates some alarms happened
<ESC> to exit

```

As above example, now there are alarms of SHDSL Links on slot 2, 5, 8, 11 and 14. User can press "A" to read all current alarms or move the cursor to the specified slot and press <CR> to read the alarms belonging to the specific link. The screen also indicates current status of the major alarms of the DSL, DTE, T1 and E1 interface of the SHDSL link.

```

** Current Alarms in slot no : ALL **      DATE : 2003/03/05
                                           TIME : 23:38:49
=====
"2003-03-05 02:15:30 MJ SLOT 2 CO DSL-LOSW"
"2003-03-05 01:56:54 MJ SLOT 2 CO ET1-LOS"
"2003-03-05 01:55:51 MJ SLOT 5 CO DSL-LOSW"
"2003-03-05 01:55:50 MJ SLOT 5 CO ET1-LOS"
"2003-03-05 01:56:15 MJ SLOT 8 CO DSL-LOSW"
"2003-03-05 01:56:14 MJ SLOT 8 CO DTE-LoDTE"
"2003-03-05 01:56:25 MJ SLOT11 CO ET1-LOS"
"2003-03-05 01:56:48 MJ SLOT14 CO DTE-LoDTE"

press any key to continue...█

```

As above example, it displays the output of CID after pressing "A" to read all alarms in <G.SHDSL\Surveillance\Retrieve Alarm> screen. From left to right, the columns sequentially indicate the date, time, severity, slot no, CO/RT, and interface to which the alarm type happened.

**Dynamix 3000 G.SHDSL TDM Based Rack
Bridged Ethernet, G.703 E1, DataCom V.35, X.21, RS-530, & RS-449 over SHDSL**

Table 5.8 Alarms & Events of DYNAMIX 3000

ALARM TYPE	Severity	Description
DSL LOSW	MJ	DSL Lost of frame
DSL ES	MN	ES threshold violation in loop
DSL SES	MN	SES threshold violation in loop
DSL UAS	MJ	UAS threshold violation in loop
LOSS OF DTE	MJ	Loss of RTS in DTE
E1 RAI	MN	RAI received in E1 interface
E1 AIS	MJ	AIS received in E1 interface
E1 LOF	MJ	Loss of frame in E1 interface
E1 LOS	MJ	Loss of signal in E1 interface
E1 ES	MN	ES threshold violation in E1
E1 SES	MN	SES threshold violation in E1
E1 UAS	MJ	UAS threshold violation in E1
T1 RAI	MN	RAI received in T1 interface
T1 AIS	MJ	AIS received in T1 interface
T1 LOF	MJ	Loss of frame in T1 interface
T1 LOS	MJ	Loss of signal in T1 interface
T1 ES	MN	ES threshold violation in T1
T1 SES	MN	SES threshold violation in T1
T1 UAS	MJ	UAS threshold violation in T1
Link Broken	MN	Loop disconnected
Plug	Event	The STU is inserted into the shelf
Unplug	Event	The STU was removed from the shelf

5.6.2 Status Read Out

When “2” is pressed to select Retrieve Status functional group in the G.SHDSL\Surveillance screen, the following menu-driven menu is presented.

```
*** G.shdsl Central Control System ***          DATE : 2003/04/10
                                                TIME  : 14:33:13
```

```
=====
G.shdsl\Surveillance\Retrieve Status :
```

- [1] System Setting
- [2] E1-T1 Interface
- [3] DTE Interface Setting
- [4] DSL Interface Setting
- ESC Go back 1 level
- [M] Go back main menu
- [L] Logout

```
select one :█
```

Four

options are available, system setting, E1-T1 interface, and DTE interface setting and DSL interface setting. They are presented as follow sub-sections.

**Dynamix 3000 G.SHDSL TDM Based Rack
Bridged Ethernet, G.703 E1, DataCom V.35, X.21, RS-530, & RS-449 over SHDSL**

5.6.2.1 Retrieve System Setting

```

*** G.shdsl\Surveillance\System Setting ***
=====
Slot Interface      Line   In      Payload  _Pclock_  Machine
ID.  CO      RT      Rate   Service  Min Max   CO  RT    ID.
=====
1
2  *S-E1    S-V35   N/A    YES      --  11    E1   DSL   STU2
3
4
5  *S-E1    S-E1    832K   YES      --  12    E1   DSL   STU11
6
7
8  *S-V35   S-V35   N/A    YES      3   36    V35  DSL   STU6
9
10
11 *S-T1    S-T1    1536K  YES      --  24    T1   DSL   STU1
12
13
14
15
=====
<ESC> to exit

```

Please refer to section 5.5.1 to see the definitions of each parameter.

5.6.2.2 Retrieve E1-T1 Interface

```

*** G.shdsl\Surveillance\E1-T1 Interface Setting ***
=====
Slot Interface      Frame   Line Code  _LBO_
ID.  CO      RT      Format   CO  RT      CO  RT
=====
1
2  *S-E1    S-V35   FAS-CRC  HDB3  --      --  --
3
4
5  *S-E1    S-E1    FAS-CRC  HDB3  HDB3   --  --
6
7
8  *S-V35   S-V35   --        --     --     --  --
9
10
11 *S-T1    S-T1    ESF       B8Z5  HDB3   L0  L0
12
13
14
15
=====
<ESC> to exit

```

Please refer to section 5.5.2 to see the definitions of each parameter.

**Dynamix 3000 G.SHDSL TDM Based Rack
Bridged Ethernet, G.703 E1, DataCom V.35, X.21, RS-530, & RS-449 over SHDSL**

5.6.2.3 Retrieve DTE Interface Setting

```

*** G.shdsl\Surveillance\DTE Interface Setting ***
=====
Slot Interface      Data Polarity      _____RTS_____
ID.  CO      RT      CO      RT      CO      RT
-----
1
2  *S-E1    S-V35  --      NORMAL  --      NORMAL
3
4
5  *S-E1    S-E1   --      --      --      --
6
7
8  *S-V35   S-V35  NORMAL  NORMAL  NORMAL  NORMAL
9
10
11 *S-T1    S-T1   --      --      --      --
12
13
14
15
=====
<ESC> to exit

```

Please refer to section 5.5.3 to see the definitions of each parameter.

5.6.2.4 Retrieve DSL Interface Setting

```

*** G.shdsl\Surveillance\DSL Interface Setting ***
=====
Slot Interface      Worst Case Line    Power      Power      Backoff
ID.  CO      RT      Target SNR  Probe  Backoff  CO      RT      ___PSD___
-----
1
2  *S-E1    S-V35  0          ON     Default  0      0      Symmetric
3
4
5  *S-E1    S-E1   0          ON     Default  0      0      Symmetric
6
7
8  *S-V35   S-V35  0          ON     Default  0      0      Symmetric
9
10
11 *S-T1    S-T1   0          ON     Default  0      0      Symmetric
12
13
14
15
=====
<ESC> to exit

```

Please refer to section 5.5.4 to see the definitions of each parameter.

**Dynamix 3000 G.SHDSL TDM Based Rack
Bridged Ethernet, G.703 E1, DataCom V.35, X.21, RS-530, & RS-449 over SHDSL**

5.6.3 Retrieve PM

*** G.shdsl Loop PM Since Reset *** Elapsed Time: 634
<auto scan = ENABLE >

```

=====
slot Interface
Id. CO RT CO RT CO RT CO RT
-----
1
2 *S-E1 S-V35 0 0 0 0 53600 0
3
4
5 *S-E1 S-E1 0 0 0 0 0 434
6
7
8 *S-V35 S-V35 0 0 0 0 53615 0
9
10
11 *S-T1 S-T1 4 16 3 0 0 239
12
13
14
15
=====

```

Legend : [A] for auto PM display switch toggle, [N] for next page
<ESC> to exit

After

pressing "3" to select Retrieve PM functional group in the G.SHDSL\Surveillance screen, the automatically changing cursor-control screen is presented. The changing rate is 10 sec per screen. Press "A" to stop/enable changing PM screen, or "N" to switch to the next screen directly. There are 6 kinds of PM screens. They are:

- E1-T1 PM since reset
- Current 15-Min PM of E1-T1
- Current 1-Day PM of E1-T1
- SHDSL LOOP PM since reset
- Current 15-Min PM of G.SHDSL LOOP
- Current 1-Day PM of G.SHDSL LOOP

In each screen, moving the cursor to the specified link and pressing <CR> can retrieve previous PM log data.

**Dynamix 3000 G.SHDSL TDM Based Rack
Bridged Ethernet, G.703 E1, DataCom V.35, X.21, RS-530, & RS-449 over SHDSL**

5.6.3.1 Current 15-Min PM of G.SHDSL LOOP

```

*** Current 15-Min PM of G.shdsl Loop *** Elapsed Time: 201
                                           <auto scan = ENABLE >
=====
Slot Interface      ES      SES      UAS      LOSWS
Id.  CO   RT      CO   RT      CO   RT      CO   RT
-----
1
2
3
4 *S-T1  S-V35  0    0    0    0    181  0    181  0
5
6
7
8 *S-V35  S-V35  0    0    0    0    182  0    182  0
9
10
11
12
13
14
15
=====
Legend : [A] for auto PM display switch toggle, [N] for next page
         <CR> to retrieve previous PM data, <ESC> to exit

```

Above example displays several kinds of DSL link PM of the current 15-Min period. Move the cursor to the specified slot and press <CR>, at most 96 PM logs in 15-Min interval of the specified DSL link are presented. In the following example, there is only one 15-Min PM logged since system starts.

```

*** Previous 15-Min PM of G.shdsl Loop *** Slot ID: 8
                                           Valid Interval: 1
=====
Interval ES      SES      UAS      LOSWS
ID.      CO   RT      CO   RT      CO   RT      CO   RT
-----
1        0    0    0    0    29  0    29  0
=====
press any key to continue...█

```

**Dynamix 3000 G.SHDSL TDM Based Rack
Bridged Ethernet, G.703 E1, DataCom V.35, X.21, RS-530, & RS-449 over SHDSL**

5.6.3.2 Current 1-Day PM of G.SHDSL LOOP

```

*** Current 1-Day PM of G.shdsl Loop ***      Elapsed Time: 76
                                                <auto scan = ENABLE >
=====
Slot Interface      ES      SES      UAS      LOSWS
Id.  CO   RT    CO   RT    CO   RT    CO   RT
-----
1
2
3
4  *S-T1  S-V35  0    0    0    0    54   0    54   0
5
6
7
8  *S-V35  S-V35  0    0    0    0    55   0    55   0
9
10
11
12
13
14
15
=====
Legend : [A] for auto PM display switch toggle, [N] for next page
<CR> to retrieve previous PM data, <ESC> to exit

```

Above example shows several kinds of DSL link PM of the current 1-Day period. Press <CR> to get the previous DSL Link PM of 1-Day interval as in the following figure.

```

*** Previous 1-Day PM of G.shdsl Loop ***      Slot ID: 8
                                                Valid Interval: 1
=====
Interval ES      SES      UAS      LOSWS
ID.      CO   RT    CO   RT    CO   RT    CO   RT
-----
1        0    0    0    0    29   0    29   0
=====
press any key to continue...

```

Dynamix 3000 G.SHDSL TDM Based Rack
Bridged Ethernet, G.703 E1, DataCom V.35, X.21, RS-530, & RS-449 over SHDSL

5.6.3.3 Current 15-Min PM of E1-T1

```

*** Current 15-Min PM of E1-T1 Interface *** Elapsed Time: 692
                                           <auto scan = ENABLE >
=====
Interface  _ES_  _SES_  _UAS_  _CRC Error_  _BPV_
ID CO   RT   CO RT   CO RT   CO   RT   CO   RT
-----
1
2
3
4
5
6 M-V35 M-V35 -- -- -- -- -- -- -- -- -- --
7
8
9 M-E1  M-V35 0  -- 0  -- 692 -- 0  -- -- 0  --
10
11
12
13
14
15
=====
Legend : [A] for auto PM display switch toggle, [N] for next page
<CR> to retrieve previous PM data, <ESC> to exit

```

Above example displays several kinds of E1-T1 Interface PM of the current 15-Min period. Move the cursor to the specified slot and press <CR>, at most 96 PM logs in 15-Min interval of the E1-T1 Interface of the specified link are displayed. In the following example, there are only 2 PM logs since system starts.

```

*** Previous 15-Min PM of E1-T1 Interface *** Slot ID: 9
                                           Valid Interval: 2
=====
Interval  _ES_  _SES_  _UAS_  _CRC Error_  _BPV_
ID.       CO   RT   CO RT   CO RT   CO   RT   CO   RT
-----
1         0  --  0  --  899 --  0  --  0  --
2         0  --  0  --  843 --  0  --  0  --

```

press any key to continue...

**Dynamix 3000 G.SHDSL TDM Based Rack
Bridged Ethernet, G.703 E1, DataCom V.35, X.21, RS-530, & RS-449 over SHDSL**

5.6.3.4 Current 1-Day PM of G.SHDSL LOOP

```

*** Current 1-Day PM of E1-T1 Interface ***           Elapsed Time: 48015
                                                    <auto scan = DISABLE>
=====
Slot Interface      ES          SES          UAS
Id. CO   RT    CO   RT    CO   RT    CO   RT
-----
 1
 2 *S-E1   S-V35   0     --    0     --    3162  --
 3
 4
 5 *S-E1   S-E1    0     0     0     0     3149  3103
 6
 7
 8 *S-V35   S-V35   --    --    --    --    --    --
 9
10
11 *S-T1    S-T1    0     0     0     0     3102  3072
12
13
14
15
=====
Legend : [A] for auto PM display switch toggle, [N] for next page
<CR> to retrieve previous PM data. <ESC> to exit

```

Above example shows several kinds of E1-T1 Interface PM of the current 1-Day period. After pressing <CR>, the previous E1-T1 Interface PM of 1-Day interval is displayed as the next figure.

```

*** Previous 1-Day PM of E1-T1 Interface ***           Slot ID: 5
                                                    Valid Interval: 0
=====
Interval ES          SES          UAS
Id. CO   RT    CO   RT    CO   RT
-----
press any key to continue...

```

5.6.4 DSL SNR and Loop Atten

When “4” is pressed to select Retrieve SNR functional group in the G.SHDSL\Surveillance screen, the following cursor control menu shows.

**Dynamix 3000 G.SHDSL TDM Based Rack
Bridged Ethernet, G.703 E1, DataCom V.35, X.21, RS-530, & RS-449 over SHDSL**

```

*** G.shdsl\Surveillance\DSL SNR and Loop Atten ***
=====
Slot Interface      SNR Margin      Loop Atten
ID.  CO   RT      CO   RT      CO   RT
-----
1
2 *S-E1   S-V35   0    0        0    0
3
4
5 *S-E1   S-E1    18   17       0    0
6
7
8 *S-V35  S-V35   0    0        0    0
9
10
11 *S-T1   S-T1    15   12       3    3
12
13
14
15
=====
<ESC> to exit

```

SNR (signal-to-noise ratio) and loop attenuation are updated as the screen refreshes. As above example, the slot 11 explicitly shows the value of DSL SNR & Loop Attenuation in CO & RT side.

5.6.5 Retrieve & Reset Event Logs

When “5” is pressed to select Retrieve & Reset Event Logs functional group in the G.SHDSL\Surveillance screen, the following cursor control menu is presented.

```

*** G.shdsl\Surveillance\Retrieve Event Logs ***
=====
Slot Interface      Read   Reset
Id.  CO   RT      Logs  Logs
-----
1
# 2 *S-E1   S-V35   <CR>  <CR>
3
4
# 5 *S-E1   S-E1    <CR>  <CR>
6
7
# 8 *S-V35  S-V35   <CR>  <CR>
9
10
#11 *S-T1   S-T1    <CR>  <CR>
12
13
14
15
=====
Legend : [R] to read all logs, <CR> to read logs in the slot
        '#' indicates some events happened
<ESC> to exit

```

As in the above example, both slot 2,5, 8 and slot 11 of the G.SHDSL Links have event in the event logs. This is indicated by the symbol # to the left of the slot id. One can press “R” to read all event logs, or can move the cursor to the specified place and press <CR> to read or reset the event logs belong to the specific link.

**Dynamix 3000 G.SHDSL TDM Based Rack
Bridged Ethernet, G.703 E1, DataCom V.35, X.21, RS-530, & RS-449 over SHDSL**

** Current Events in slot no. : 2 ** DATE : 2003/03/27
 TIME : 13:24:23

```
=====
"2003-03-27 12:27:35 000003 SLOT 2 CO DSL-LOS"
"2003-03-27 12:27:35 000002 SLOT 2 CO ET1-LOS"
"2003-03-27 12:27:35 000001 SLOT 2 CO PLUG"
```

press any key to continue...

Shown in the above example, is the result after the user pressed "R" to read all event logs in <G.SHDSL\Surveillance\Retrieve & Reset Event Logs> screen. The columns from left to right indicate the following information: the event happening day and time, the tag of the event, which interface (slot no-STU-CO/RT-interface), the name of the alarm.

```

*** G.shdsl\Surveillance\Retrieve Event Logs ***
=====
slot Interface      Read      Reset
Id.  CO      RT      Logs      Logs
-----
  1
# 2 *S-E1    S-V35    <CR>     <CR>
  3
  4
  5 *S-T1    S-V35    <CR>     <CR>
  6
  7
# 8 *S-V35   S-V35    <CR>     <CR>
  9
 10
#11 *S-E1    S-E1     <CR>     <CR>
 12
 13
 14
 15
=====
Are you sure(Y/N)?█

```

Above example displays the event logs of the slot 8 has been reset when cursor was moved to the Reset Logs location and pressed <CR>.

**Dynamix 3000 G.SHDSL TDM Based Rack
Bridged Ethernet, G.703 E1, DataCom V.35, X.21, RS-530, & RS-449 over SHDSL**

5.6.6 Retrieve Version

When “6” is pressed to select Retrieve Version functional group in the G.SHDSL\Surveillance screen, the following cursor control menu is presented.

```

*** G.shdsl\surveillance\Retrieve Version ***
MIU S/W: 0.09
H/W: 1.1
=====
Slot Interface  _S/W Ver._  H/W Ver.  _FPGA_  DSP CHIP  DSP CODE
Id.  CO    RT    CO    RT    CO  RT    CO  RT    CO  RT    CO  RT
=====
1
2  *S-E1  S-V35  0.51  0.51  1.1 1.1  1.1 1.1  0x12 0x00  0x96 0x00
3
4
5  *S-E1  S-E1   0.54  0.51  1.1 4.1  1.1 1.1  0x12 0x12  0x96 0x16
6
7
8  *S-V35 S-V35  0.51  0.51  1.1 1.1  1.1 1.1  0x12 0x00  0x96 0x00
9
10
11 *S-T1  S-T1   0.51  0.54  1.1 4.1  1.1 1.1  0x12 0x12  0x96 0x16
12
13
14
15
=====
<ESC> to exit

```

In the above example, the CID displays the version for the type of DSP code, the S/W version for CO and RT, the H/W version for CO and RT, DSP CHIP version for CO and RT, and FPGA version for CO and RT.

Dynamix 3000 G.SHDSL TDM Based Rack
Bridged Ethernet, G.703 E1, DataCom V.35, X.21, RS-530, & RS-449 over SHDSL

5.6.7 Reset PM Data

When “7” is pressed to select Reset PM functional group in the G.SHDSL\Surveillance screen, the following cursor control menu is presented.

```
*** G.shdsl\Surveillance\Reset PM ***
=====
Slot Interface      Activate
Id.  CO      RT      Reset Operation
-----
 1
 2 *S-E1    S-V35  <CR>
 3
 4
 5 *S-T1    S-T1    <CR>
 6
 7
 8 *S-V35   S-V35   <CR>
 9
10
11 *S-E1    S-E1    <CR>
12
13
14
15
=====
      In Processing, please wait..
```

As shown in the above figure, move the cursor to the specified slot under the Activate Reset Operation header and press <CR> to clear the specific link's PM data.

5.7 Maintenance

After pressing “3” in the main menu, CID screen changes to the G.SHDSL Maintenance screen.

```

*** G.shdsl Central Control system ***          DATE : 2003/03/27
                                                TIME : 13:29:00
=====
G.shdsl\Maintenance :
    [1] Loopback Control
    [2] PRBS
    [R] Retrieve new events
    ESC Go back 1 level
    [M] Go back main menu
    [L] Logout
select one :
    
```

<< New events happen >>

There are 3 functional groups in the G.SHDSL Maintenance screen. The following sections describe the functions in more detail

5.7.1 Loopback Control

After pressing “1” to select Loopback Control functional group in the G.SHDSL Maintenance screen, the following menu is presented to the operator.

```

*** G.shdsl\Maintenance\Loopback ***
=====
slot Interface
Id.  CO    RT      Loopback Config/Status
-----
 1
 2  *S-E1  S-V35   Disable
 3
 4
 5  *S-E1  S-E1    Disable
 6
 7
 8  *S-V35 S-V35   Disable
 9
10
11  *S-T1  S-T1    Disable
12
13
14
15
=====
Legend : (1)Disable (2)NearEndLB (3)LocalLB (4)ReomteLB
         (5)PayloadLB
<ESC> to exit
    
```

The

DYNAMIX 3000 system provides several kinds of loopback to enable user to verify the link and system integrity. Refer to Sec 2.8 for details concerning available loopbacks. When the local unit is performing the loopback, the TST led will remain on until the test is deactivated and the remote unit’s TST led will be flashing. Table 5.8 lists all the available loopbacks for DYNAMIX 3000 system. Different interfaces have different points where loopback is performed. Appendix D has detailed loopback points in relation to SHDSL system configuration.

**Dynamix 3000 G.SHDSL TDM Based Rack
Bridged Ethernet, G.703 E1, DataCom V.35, X.21, RS-530, & RS-449 over SHDSL**

Table 5.8 Loopback Control Parameter Descriptions

Parameter Name	R/W	Interface Type	Legal Value	Description
Interface-CO	RO	-	-	Indicate current CO side interface.
Interface-RT	RO	-	-	Indicate current RT side interface.
Loopback	R/W	S-ETH S-E1 S-T1 S-V35	(1) Disable (2) NearEndLB (3) LocalLB (4) RemoteLB (5) PayloadLB (6) ActiveV54toDSL	1. Disable: disables the loopback test 2. NearEndLB: please refer to section 2.8.1 3. LocalLB: please refer to section 2.8.2 4. RemoteLB: please refer to section 2.8.3 5. PayloadLB: please refer to section 2.8.4 6. only S-V35 can execute ActiveV54toDSL Note: only Ethernet Loopback can execute LocalLB and RemoteLB.

5.7.2 PRBS Test

After pressing “2” to select PRBS Test functional group in the G.SHDSL\Maintenance screen, the following menu is presented to operator.

```

*** G.shdsl\Maintenance\PRBS Test ***
=====
Slot Interface      Inject 1      Elapsed      Bit Error
Id.  CO      RT      PRBS      Error Bit  Resync Status Time      Count
-----
1
2  *S-E1    S-V35  toDSL    <CR>      <CR>      Unsync  00:00:32  0
3
4
5  *S-T1    S-T1    OFF      --        --        --      --      --
6
7
8  *S-V35   S-V35   OFF      --        --        --      --      --
9
10
11 *S-E1    S-E1    OFF      --        --        --      --      --
12
13
14
15
=====
Legend : press <CR> to inject 1 Error Bit
         <ESC> to exit

```

For each STU-C and STU-R, the built-in PRBS (pseudo-random binary sequence) generation and detection are provided for Loopback performance test. Test results are displayed in the PRBS screen. Click on “CR” (Enter) to start the PRBS test so that the TST LED of local SHDSL device will be lit and remote SHDSL device will flash simultaneously when receiving PRBS.

Figure 5-9 PRBS Parameter Descriptions

Parameter Name	R/W	Interface Type	Legal Value	Description
Interface-CO	RO	--	--	Indicate current CO side interface.
Interface-RT	RO	--	--	Indicate current RT side interface.
PRBS	R/W	All	(1) OFF (2) toDSL	Activate the PRBS test in CO side. 1. OFF : stop PRBS test. 2. toDSL : means to generate and detect the PRBS pattern to and from the DSL link.
Inject 1 Error Bit	W	All	<CR>	One bit error is injected in the transmit pattern when <CR> is pressed.
Resync	W	All	<CR>	The bit error count will be reset to zero when <CR> is pressed.
Elapsed Time	R	All	--	The duration since start the PRBS test
Bit Error Count	R	All	--	The accumulated bit error count since the start of PRBS test

5.8 Miscellanea

After pressing “4” in the main menu, the following menu is presented to the operator.

```
*** G.shdsl Central Control System ***          DATE : 2003/03/27
                                                TIME : 13:32:24
```

=====

```
G.shdsl\Miscellanea :
[1] Set System Time
[2] Set TCP/IP Parameters of SNMP Agent
[3] Set Screen Refresh Timer
[4] User Account Management
[R] Retrieve new events
ESC Go back 1 level
[M] Go back main menu
[L] Logout
```

select one :█

<< New events happen >>

There are 4 functional groups in the G.SHDSL\Miscellanea screen. The following sections describe the functions in more detail.

5.8.1 Set System Time

After pressing “1” to select Set System Time functional group in the G.SHDSL\Miscellanea screen, the following cursor control menu is shown.

```
*** Set System Date & Time ***
```

=====

```
** Input New Date (Current = 20030327) : █YYMMDD
   New Time (Current = 133307) : HHMMSS
```

<ESC> to exit

Dynamix 3000 G.SHDSL TDM Based Rack

Bridged Ethernet, G.703 E1, DataCom V.35, X.21, RS-530, & RS-449 over SHDSL

Follow the on screen instruction and key-in the system date and time accordingly. The system time will be set to new time after the procedure is completed.

5.8.2 Set TCP/IP parameters of SNMP agent

After pressing "2" to select Set TCP/IP parameters of SNMP agent functional group in the G.SHDSL\Miscellanea screen, the following cursor control menu is shown.

```
*** Set TCP/IP Parameters of SNMP Agent ***
=====

IP Addr.                (192.168. 0.236) : █<CR>
Subnet Mask             (255.255.255. 0) : <CR>
IP Addr. of Gateway    (192.168. 0. 1) : <CR>
Trap Destination IP Addr. 1 (192.168.100. 1) : <CR>
Trap Destination IP Addr. 2 (192.168.100. 2) : <CR>
Trap Destination IP Addr. 3 (192.168.100. 3) : <CR>
Trap Destination IP Addr. 4 (192.168.100. 4) : <CR>
Trap Destination IP Addr. 5 (192.168.100. 5) : <CR>
Save to FLASH          : <CR>

Legend : press <CR> to enter
        <ESC> to exit
```

Move the cursor to the specified parameter position and press <CR>, and then follow the on screen instruction to input the desired value.

5.8.3 Set Screen Refresh Timer

After pressing "3" to select Set Screen Refresh Timer in the G.SHDSL\Miscellanea screen, the following cursor control menu is shown.

```
*** Set Screen Refresh Timer ***
=====

** Input New Refresh Time (current = 10s) : █

<ESC> to exit
```

By setting Screen Refresh Timer, users can retrieve the latest information in real time in the screen. Press <CR> to Input new refresh time.

5.8.4 User Account Management

After pressing “4” to select **User Account Management** in the G.SHDSL Miscellaneous screen, four options, Users’ Account Information, add user account, modify user account and delete user account, are available to change as the following screen shown.

```
*** User Account Management ***
=====
Users' Accounts Information : <CR>
Add User Account           : <CR>
Modify User Account        : <CR>
Delete User Account        : <CR>

Legend : press <CR> to enter
        <ESC> to exit
```

5.8.4.1 Users’ Accounts Information

after pressing <CR> in “Users’ Accounts Information” , you can read the registered user information as the following screen shown.

```
*** User Account Management ***
=====
NO          User name          Privilege
-----
1           admin             administrator
-----

press any key to continue...█
```

5.8.4.2 Add User Account

After pressing <CR> in “Add User Account”, you can add user account as the following screen shown:

```

***   User Account Management   ***
=====

Users' Accounts Information   : <CR>
Add User Account             : <CR>
Modify User Account          : <CR>
Delete User Account          : <CR>

                                User Name : mike
                                User privilege : 1
([1]administrator|[2]operator|[3]guest)
                                Password : *****
                                Confirm  : *****

Account(mike) added.

press any key to continue...
    
```

As the example shows, User Name, User Privilege, password and confirm are requested to key in. The following privilege matrix will help users to understand the differences of different user privilege.

Command	User Privilege
ALL Configuration	Operator/Admin
ALL Surveillance (except reset log and reset PM)	Guest/Operator/Admin
Reset log and Reset PM	Operator/Admin
ALL Maintenance	Operator/Admin
Set System Time	Operator/Admin
Set TCP/IP Parameters of SNMP Agent	Admin
Set Screen Refresh Timer	Guest/Operator/Admin
User Account Management	Admin

5.8.4.3 Modify User Account

After pressing <CR> in the “Modify User Account”, user account could be modified.

```
*** User Account Management ***
=====
Users' Accounts Information : <CR>
Add User Account           : <CR>
Modify User Account        : <CR>
Delete User Account        : <CR>

User Name : mike
User privilege : 3
([1]administrator|[2]operator|[3]guest)
Password : ****
Confirm : ****

Account(mike) modified.
press any key to continue...
```

By keying in the user name, user privilege and password could be modified thereafter.

5.8.4.4 Delete User Account

After pressing <CR> in the “Delete User Account”, user account could be deleted.

```
*** User Account Management ***
=====
Users' Accounts Information : <CR>
Add User Account           : <CR>
Modify User Account        : <CR>
Delete User Account        : <CR>

User Name : mike
Delete User (y/n): y

Account(mike) deleted.
press any key to continue...█
```

By keying in “User Name”, a specified user could be deleted.

5.9 Retrieve New Event

When <<New Event Happen>> icon in the lower right hand corner of the menu-driven screen is showing and flashing. User can press "R" to retrieve new events in only menu-driven screens. The icon will disappear when this function is completed and display again when there are any new event happening.

```
*** G.shdsl Central Control System ***          DATE : 2003/03/27  
                                                TIME : 13:32:24
```

```
=====
```

```
G.shdsl\Miscellanea :
```

```
[1] Set System Time  
[2] Set TCP/IP Parameters of SNMP Agent  
[3] Set Screen Refresh Timer  
[4] User Account Management  
[R] Retrieve new events  
ESC Go back 1 level  
[M] Go back main menu  
[L] Logout
```

```
select one :█
```

<< New events happen>> The following

screen shows new events in all slots.

```
*** New Events in ALL slot ***  
=====
```

```
"2003-03-27 13:35:14 000066 SLOT11 RT ET1-AIS"  
"2003-03-27 13:33:59 000065 SLOT11 RT ET1-AIS"  
"2003-03-27 13:32:44 000064 SLOT11 RT ET1-AIS"  
"2003-03-27 13:32:07 000063 SLOT11 RT ET1-AIS"  
"2003-03-27 13:30:31 000062 SLOT11 RT ET1-AIS"  
"2003-03-27 13:29:24 000061 SLOT11 RT ET1-AIS"  
"2003-03-27 13:27:51 000060 SLOT11 RT ET1-AIS"  
"2003-03-27 13:27:13 000059 SLOT11 RT ET1-AIS"  
"2003-03-27 13:26:15 000058 SLOT11 RT ET1-AIS"  
"2003-03-27 13:24:42 000057 SLOT11 RT ET1-AIS"  
"2003-03-27 13:23:06 000056 SLOT11 RT ET1-AIS"  
"2003-03-27 13:22:28 000055 SLOT11 RT ET1-AIS"  
"2003-03-27 13:14:06 000049 SLOT11 RT ET1-AIS"  
"2003-03-27 13:13:28 000048 SLOT11 RT ET1-AIS"  
"2003-03-27 13:12:14 000047 SLOT11 RT ET1-AIS"  
"2003-03-27 13:10:59 000046 SLOT11 RT ET1-AIS"
```

press any key to continue...

Appendix A: Interface Pin Assignments

DTE Interface Pin Assignment Table

EIA DESCRIPTION	ABBR.	SIGNAL TO	V.35	EIA-530	RS-449	X.21
Shield			A	1	1	Case
Signal Gnd	SG		B	7	19	8
DTE Common RTN					37	
DCE Common RTN					20	
Transmit Data (A)	TD(A)	DCE	P	2	4	2
Transmit Data (B)	TD(B)	DCE	S	14	22	9
Receive Data (A)	RD(A)	DTE	R	3	6	4
Receive Data (B)	RD(B)	DTE	T	16	24	11
Request To Send (A)	RTS(A)	DCE	C	4	7	3
Request To Send (B)	RTS(B)	DCE		19	25	10
Clear To Send (A)	CTS(A)	DTE	D	5	9	
Clear To Send (B)	CTS(B)	DTE		13	27	
Data Set Ready (A)	DSR(A)	DTE	E	6	11	
Data Set Ready (B)	DSR(B)	DTE		22	29	
Data Terminal Ready (A)	DTR(A)	DCE	H	20	12	
Data Terminal Ready (B)	DTR(B)	DCE		23	30	
Data Carrier Detect (A)	DCD(A)	DTE	F	8	13	5
Data Carrier Detect (B)	DCD(B)	DTE		10	31	12
Terminal Transmit Clock (A)	TTC(A)	DCE	U	24	17	7
Terminal Transmit Clock (B)	TTC(B)	DCE	W	11	35	14
Transmit Clock (A)	TC(A)	DTE	Y	15	5	
Transmit Clock (B)	TC(B)	DTE	AA	12	23	
Receive Clock (A)	RC(A)	DTE	V	17	8	6
Receive Clock (B)	RC(B)	DTE	X	9	26	13
Remote Loopback	RLB	DCE	N	21	14	
Local Loopback	LLB	DCE	L	18	10	
Test Mode	TM	DTE	NN	25	18	

CID (RS-232) PIN ASSIGNMENT TABLE

EIA DESCRIPTION	ABBR.	SIGNAL TO	RS-232
Signal Gnd	SG		5
Transmit Data (A)	TD(A)	DCE	3
Receive Data (A)	RD(A)	DTE	2
Request To Send (A)	RTS(A)	DCE	7
Clear To Send (A)	CTS(A)	DTE	8
Data Set Ready (A)	DSR(A)	DTE	6
Data Terminal Ready (A)	DTR(A)	DCE	4
Data Carrier Detect (A)	DCD(A)	DTE	1

**Dynamix 3000 G.SHDSL TDM Based Rack
Bridged Ethernet, G.703 E1, DataCom V.35, X.21, RS-530, & RS-449 over SHDSL**

E1 and T1 INTERFACE PIN ASSIGNMENT TABLE

SIGNAL DESCRIPTION	DIRECTION	DB-15	TERMINAL BLOCK	RJ-45
TTIP	OUT	1	T	1
TRING	OUT	9	R	2
RTIP	IN	3	T1	4
RRING	IN	11	R1	5
Frame Ground		2	GND	3
		4		6

Dynamix 3000 G.SHDSL TDM Based Rack
Bridged Ethernet, G.703 E1, DataCom V.35, X.21, RS-530, & RS-449 over SHDSL

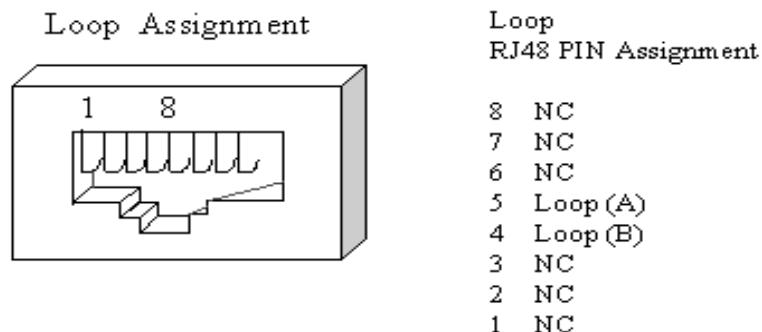
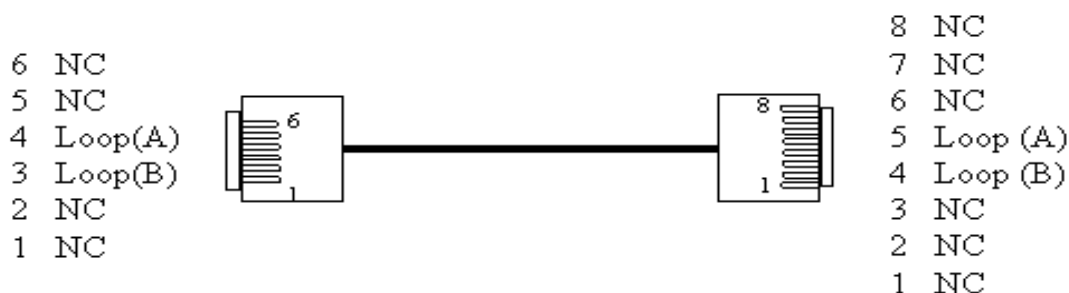
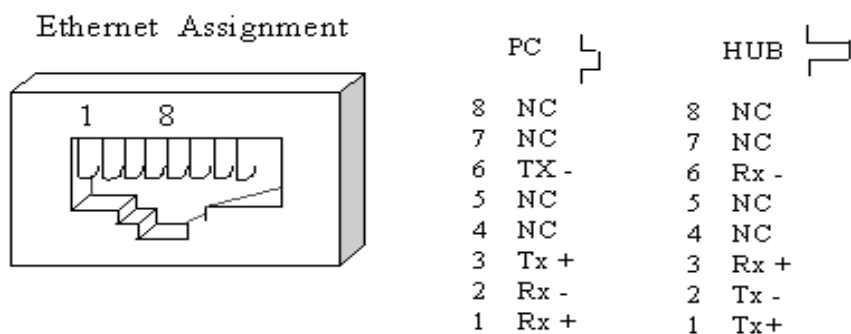

APPENDIX B: Acronym Definitions

The definitions for the Alarms and PM acronyms:

DSLLOS	The Loop is in Loss of Sync state when in Alarm state.
DSLLOS W	Loss of Sync Word, the DSL SYNC word received was corrupted and when this occurs continuously for more than 2 seconds, DSLLOS will be declared.
DSLLOSD	Far end user interface is not active when in Alarm state.
DSLsnr	Received DSL SNR value is lower than set value.
DSLAttn	DSL attenuation value is higher than set value.
DSLUAS 15Min	PM Threshold alarm for 15-Minute count. Alarm will active when DSLUAS value for the 15-minute interval is larger than set threshold value.
DSLSES 15Min	PM Threshold alarm for 15-Minute count. Alarm will active when DSLSES value for the 15-minute interval is larger than set threshold value.
DSLES15 Min	PM Threshold alarm for 15-Minute count. Alarm will active when DSLES value for the 15-minute interval is larger than set threshold value.
DSLUAS Day	PM Threshold alarm for 1-Day count. Alarm will active when DSLUAS value for the 1-Day interval is larger than set threshold value.
DSLSES Day	PM Threshold alarm for 1-Day count. Alarm will active when DSLSES value for the 1-Day interval is larger than set threshold value.
DSLES Day	PM Threshold alarm for 1-Day count. Alarm will active when DSLES value for the 1-Day interval is larger than set threshold value.
DTELOS	Local DTE or Ethernet user interface is not active when in Alarm state.
ET1LOS	The E1 or T1 interface does not have input signal, Loss of Signal (LOS).
ET1LOF	The E1 or T1 interface cannot obtain the input frame, Loss of Frame (LOF).
ET1AIS	The E1 or T1 interface is receiving an Alarm Indicator Signal.
ET1RAI	The E1 or T1 interface is receiving a Yellow alarm or Remote Alarm Indication (RAI).
ET1UAS 15Min	PM Threshold alarm for 15-Minute count. Alarm will active when ET1UAS value for the 15-minute interval is larger than set threshold value.
ET1SES1 5Min	PM Threshold alarm for 15-Minute count. Alarm will active when ET1SES value for the 15-minute interval is larger than set threshold value.
ET1ES15 Min	PM Threshold alarm for 15-Minute count. Alarm will active when ET1ES value for the 15-minute interval is larger than set threshold value.
ET1UAS Day	PM Threshold alarm for 1 Day count. Alarm will active when ET1UAS value for the 1-Day interval is larger than set threshold value.
ET1SES	PM Threshold alarm for 1 Day count. Alarm will

Dynamix 3000 G.SHDSL TDM Based Rack

Bridged Ethernet, G.703 E1, DataCom V.35, X.21, RS-530, & RS-449 over SHDSL

Day	active when ET1SES value for the 1-Day interval is larger than set threshold value.
ET1ES	PM Threshold alarm for 1 Day count. Alarm will
Day	active when ET1ES value for the 1-Day interval is larger than set threshold value.

APPENDIX C: Ethernet Interface Setting

Two Ethernet Interfaces are available in DYNAMIX 3000: 10 BaseT Ethernet Interface and 10/100 BaseT Ethernet Interface. They will be introduced separately in the following section.

■ **10 BaseT Ethernet:**

There are two dip switches on the back of the SHDSL unit, where the 10 BaseT Ethernet Interface is. The two dip switches select the following parameters:

Switch 1: Enable or disable the tinygram compression algorithm.

When enabled on both sides, this will improve the transfer rate of small packets. Since it will not transmit the stuff bytes required forming a fixed length packet.

Switch 2: Enable or disable the filtering of the etherbridge.

Filter and forward is the main function of the etherbridge, where it learns all the MAC addresses and store it in LAN table of up to 10,000 addresses. When enabled, it will forward those frames destined for outside of LAN. When disabled, it will transparently pass all frames over to the other side.

Switch	ON	OFF	Note
1	Enable	Disable	Compression
2	Disable	Enable	Filtering

The default setting is switches 1 and 2 are both off.

The push button selects which device the 10 BaseT port is connected to. When it is pushed in, it is a direct connection to the computer and when it is in the out position, it is a direction connection to the HUB.

10 BaseT Ethernet Interface Panel

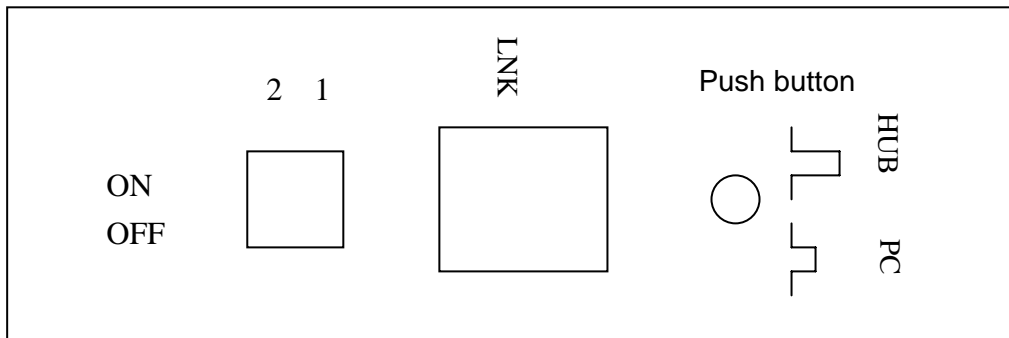

■ **10/100 BaseT Ethernet Interface:**

There are two LEDs on the panel of 10/100 BaseT Ethernet Interface: DUPLEX and 10/100.

DUPLEX: the DUPLEX LED will be green when this interface is power on; if the LED turns into red, the DUPLEX mode is activated.

10/100: red shows the speed is 10Mbps and green shows the speed is 100Mbps.

In addition, there is also a push button on the 10/100 BaseT Ethernet panel. The push

Dynamix 3000 G.SHDSL TDM Based Rack

Bridged Ethernet, G.703 E1, DataCom V.35, X.21, RS-530, & RS-449 over SHDSL

button selects which device the 10/100 BaseT port is connected to. When it is pushed in, it is a direct connection to the computer and when it is in the out position, it is a direction connection to the HUB.

10/100 BaseT Ethernet Interface

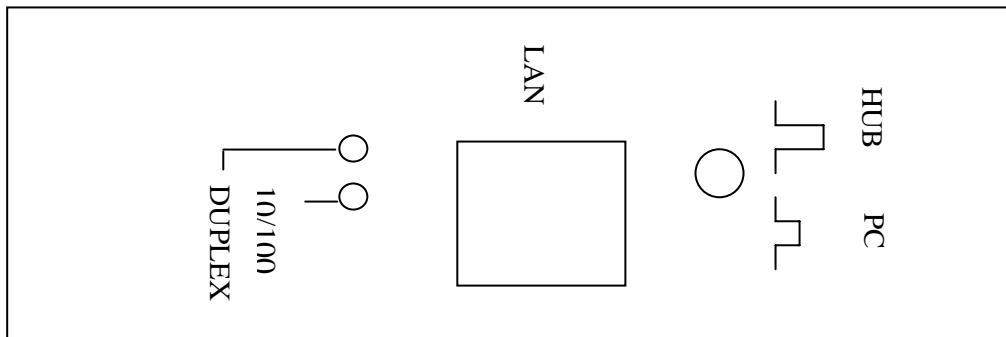

APPENDIX D: Loopback Illustration

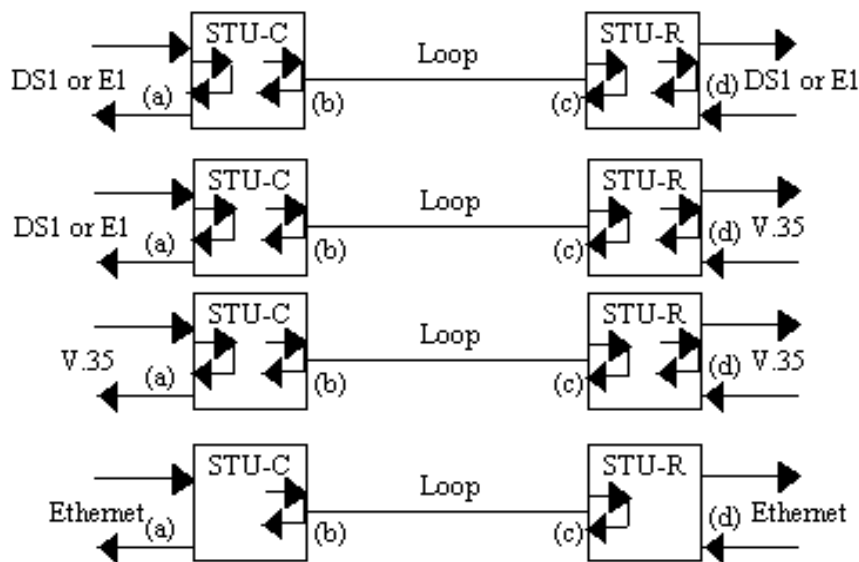

STU-C side activation loopback

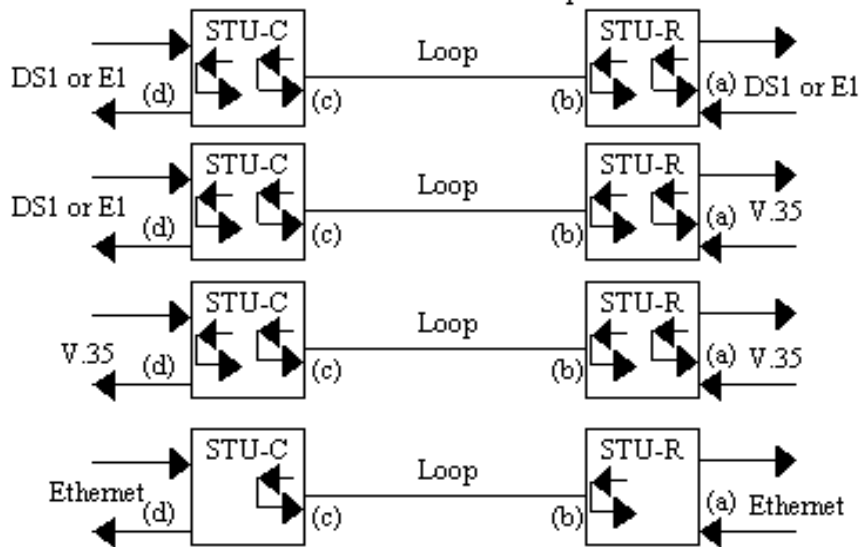

STU-R side activation loopback

(a) Near end loopback (c) Remote loopback
 (b) Local loopback (d) Remote payload loopback

Appendix E: DYNAMIX 3000 Specification

Self type	Number of cards: Port density: Network interface: Connection: Management: Power requirement: Dimension: Loop connection:	16 slots, one MIU plus up to 15 G.SHDSL line cards 1 port per line card Ethernet, EIA-530, T1 and E1; V.35, RS-449 and X.21 needs conversion cable Front access for Management and Network interface LED indicators CID/RS232 SNMP agent, management IP control list Telnet -36VDC~-72VDC 308mm(H)×483mm(W)×336mm(D) RJ-48 or Wire wrap pins
Loop Interface	Number of wire Standard Line impedance Payload rate Transmission distance	Two wires Comply ITU-T G.991.2 Annex A and B 135 ohms 192K, 256K, 384K, 512K, 768K, 1024K, 1168K, 1280K, 1544k, 2048K, 2312Kb/s for V.35 and Ethernet interfaces 4.1~7.1 km (0.4 mm wire)
Ethernet Interface	Bridge support Payload rate Connector	4K hash table N×64kb/s, 3 ≤ N ≤ 36 RJ-45
V.35 Interface	Data rate Clock source Connector/Role	N×64kb/s, 3 ≤ N ≤ 36 Internal, DSL or DTE ISO-2593 female/DCE
E1 Interface	Line code/interface Frame format Payload rate Line impedance & connector	HDB3/ITU-T G.703, 2.048 Mbps Framed and transparent N×64kb/s, 2 ≤ N ≤ 31 DB 15 pin for 120 ohms
T1 Interface	Line code/interface Frame format Payload rate Line impedance & connector	AMI, B8ZS /ANSI T1.403, 1.544 Mbps SF, ESF and Transparent N×64kb/s, 3 ≤ N ≤ 24 DB 15 pin for 100 ohms
Environment	Storage Temperature Storage Humidity Operating Temperature Operating Humidity	-40°C~60°C 5%~95% 0°C~60°C 5%~95%, none condense
Maintenance	V.54 remote loopback QRSS pattern generator	Built-in Built-in

Appendix F: Remote Control through Telnet

DYNAMIX 3000 supports only one Telnet client that you can use to connect with. Telnet provides a simple terminal emulation that allows you to see and interact with the DYNAMIX 3000 MIU. As with any remote connection, the network interface IP address for the DYNAMIX 3000 must be established. The following figure is the telnet screen to remote control DYNAMIX 3000.

